

Air Hydraulic Unit

Model CV

Model AB

Model CK

Model AC

Model CP/CPB

Model CPC/CQC

Model CB

Model CC



Hydraulic pressure can be easily generated by using factory air pressure

Wide variety from simple single circuit to multiple circuits unit with non-leak valve.

- **Easy to generate low to high hydraulic pressure**

Hydraulic pressure can be generated easily by using factory air pressure. Compact and easy to set up.

- **Safety**

If a blackout occurs and the air supply is cut off, the air hydraulic unit with a non-leak valve can hold the hydraulic pressure at the current actuator state.



- **Energy-Saving**

Pump activates when the hydraulic pressure is rising. After the hydraulic pressure reaches as specified, air pressure and hydraulic pressure are balanced then pump is stopped.

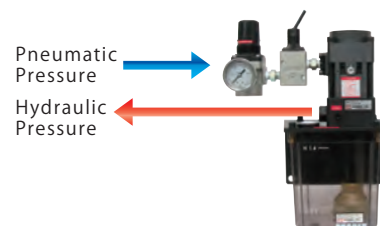





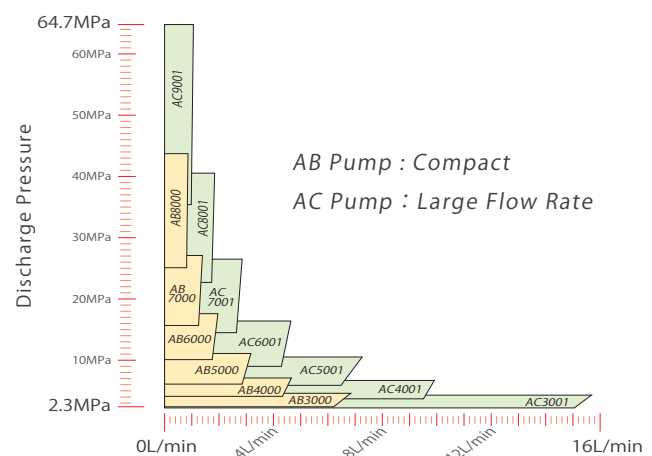

After the hydraulic pressure reaches as specified, air pressure and hydraulic pressure are balanced then pump is stopped.

- **Wide Variations**

Air driven hydraulic pump unit has a wide pressure range from low to high and discharge pressure range.



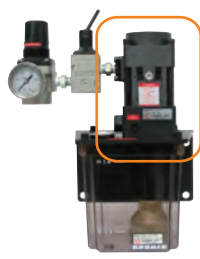

	Discharge Pressure	Features
Hydraulic Unit (For Single Action) Model CV → P.1281 	2.4~43.5MPa (AB Pump) 2.3~64.7MPa (AC Pump)	With Selector Valve for Manual Control (Standard)
Hydraulic Unit (For Double/Single Action) Model CK → P.1283 	2.4~27.0MPa (AB Pump) ※Except AB8000	
Hydraulic Unit Model CP/CPB → P.1287 	2.5~30.0MPa (AB Pump)	With Solenoid Valve for Electrical Control (Standard)
Hydraulic Unit Model CPC/CQC → P.1295 	2.5~30.0MPa (AC Pump)	
Pump Unit Model CB → P.1299 	2.4~43.5MPa (AB Pump) 2.5~30.0MPa (At BC, BH connected)	Pump & valve is assembled separately Used in conjunction with the Model BC / BH Unit
Pump Unit Model CC → P.1301 	2.3~64.7MPa (AC Pump) 2.5~30.0MPa (At BC, BH connected)	

- High-Power Series
- Pneumatic Series
- Hydraulic Series
- Valve / Coupler Hydraulic Unit**
- Manual Operation Accessories
- Cautions / Others
- Air Sequence Valve
 - BWD
- Hydraulic Non-Leak Coupler
 - BGA/BGB
 - BGC/BGD
 - BGP/BGS
 - BBP/BBS
 - BNP/BNS
 - BJP/BS
 - BFP/BFS
- Auto Coupler
 - JTA/JTB
 - JTC/JTD
 - JVA/JVB
 - JVC/JVD
 - JVE/JVF
 - JNA/JNB
 - JNC/JND
 - JLP/JLS
- Rotary Joint
 - JR
- Hydraulic Valve
 - BK
 - BEQ
 - BT
 - BLS/BLG
 - BLB
 - JSS/JS
 - JKA/JKB
 - BMA/BMG
 - AU/AU-M
 - BU
 - BP/JPB
 - BX
 - BEP/BSP
 - BH
 - BC
- Air Hydraulic Unit**
 - CV**
 - CK**
 - CP/CPB**
 - CPC/CQC**
 - CB**
 - CC**
 - AB/AB-V**
 - AC/AC-V**



AB/AC Pump

Discharge pressure and discharge amount of oil is different depending on pump.
 Please refer to AB pump/AC pump specification for details on operating pneumatic pressure, discharge pressure and discharge flow rate.

	Model No.	Discharge Pressure ^{※1} MPa	Air Consumption Nm ³ /min	Lift	Noise	Usable Fluid
AB Pump Model AB → P.1303 	AB3000	2.4 ~ 4.3	0.4 Nm ³ /min	below 0.6m	82 ~ 85dB	General Hydraulic Oil Water-Glycol Silicon Oil
	AB4000	3.9 ~ 7.0				
	AB5000	6.0 ~ 11.0				
	AB6000	10.0 ~ 17.5				
	AB7000	15.5 ~ 27.0				
	AB8000	25.0 ~ 43.5				
AC Pump Model AC → P.1303 	AC3001	2.3 ~ 4.2	1.0 Nm ³ /min	below 1.0m		
	AC4001	3.6 ~ 6.6				
	AC5001	5.8 ~ 10.6				
	AC6001	8.9 ~ 16.3				
	AC7001	14.4 ~ 26.4				
	AC8001	22.6 ~ 41.4				
	AC9001	35.3 ~ 64.7				

Note: ※1. Discharge pressure is set when air pressure range is between 0.3 ~ 0.5MPa.

Hydraulic Unit (For Single Action)

Model CV



Features

- Manual Control for Single Action (Solenoid valve option is also available.)
- Without Non-Leak Valve
- One Circuit Control Unit

Model No. Indication

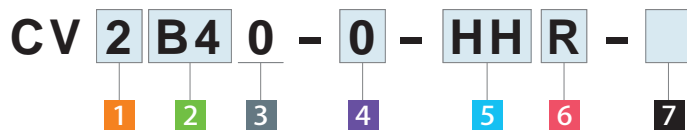

1 Tank Capacity

- 2** : 2 ℓ (Actual Amount for Use 1.1 ℓ) ※1
- 5** : 5 ℓ (Actual Amount for Use 3.1 ℓ)

※1. Only **5** : 5.0 ℓ tank is selectable for AC pump.

2 Pump Part Number (Pump Pressure Code)

- | | |
|-----------------------|-----------------------|
| B3 : AB3000-V□ | C3 : AC3001-V□ |
| B4 : AB4000-V□ | C4 : AC4001-V□ |
| B5 : AB5000-V□ | C5 : AC5001-V□ |
| B6 : AB6000-V□ | C6 : AC6001-V□ |
| B7 : AB7000-V□ | C7 : AC7001-V□ |
| B8 : AB8000-V□ | C8 : AC8001-V□ |
| | C9 : AC9001-V□ |

3 Design No.

- 0** : Revision Number

4 Fluid Code

- 0** : General Hydraulic Oil (See Hydraulic Fluid List P.1355)
- S** : Silicon Oil
- G** : Water-Glycol (except AB8000/AC8001/AC9001) (Tank is made of steel.)
- ※ Contact us for fluids other than those described in the fluid code.

5 Control Method

- HH** : Mechanical Selector Valve Option (Standard)
- 5A** : Solenoid Valve Option (DC24V)
- 1A** : Solenoid Valve Option (AC100V)
- F** : Foot Switch

6 Component Directly Mounted on the Air Supply Side

- R** : Air Regulator (Standard)
- D** : With a Filter Regulator (Automatic Drain Option)

7 Unit of Pressure Gauge

- Blank** : MPa (Standard)
- P** : PSI

Specifications

Model No.	CV□B30	CV□B40	CV□B50	CV□B60	CV□B70	CV□B80
Pump Part Number	AB3000-V□	AB4000-V□	AB5000-V□	AB6000-V□	AB7000-V□	AB8000-V□
Discharge Hydraulic Pressure ※2 MPa	2.4 ~ 4.3	3.9 ~ 7.0	6.0 ~ 11.0	10.0 ~ 17.5	15.5 ~ 27.0	25.0 ~ 43.5
Air Consumption Nm ³ /min	0.4					
Tank Capacity ℓ	2:2ℓ (Actual Amount for Use 1.1ℓ) / 5:5ℓ (Actual Amount for Use 3.1ℓ)					
Operating Temperature °C	0 ~ 70					
Usable Fluid	Depends on the Fluid Code (Model No. Indication)					

Model No.	CV5C30	CV5C40	CV5C50	CV5C60	CV5C70	CV5C80	CV5C90
Pump Part Number	AC3001-V□	AC4001-V□	AC5001-V□	AC6001-V□	AC7001-V□	AC8001-V□	AC9001-V□
Discharge Hydraulic Pressure ※2 MPa	2.3 ~ 4.2	3.6 ~ 6.6	5.8 ~ 10.6	8.9 ~ 16.3	14.4 ~ 26.4	22.6 ~ 41.4	35.3 ~ 64.7
Air Consumption Nm ³ /min	1.0						
Tank Capacity ℓ	5ℓ (Actual Amount for Use 3.1ℓ)						
Operating Temperature °C	0 ~ 70						
Usable Fluid	Depends on the Fluid Code (Model No. Indication)						

Notes : ※2. Discharge hydraulic pressure indicates when air pressure range is between 0.3 ~ 0.5MPa.

1. Please refer to the AB/AC pump performance curve for the calculation formula and the volume of discharge hydraulic pressure (P.1305).

External Dimensions / Circuit Symbol

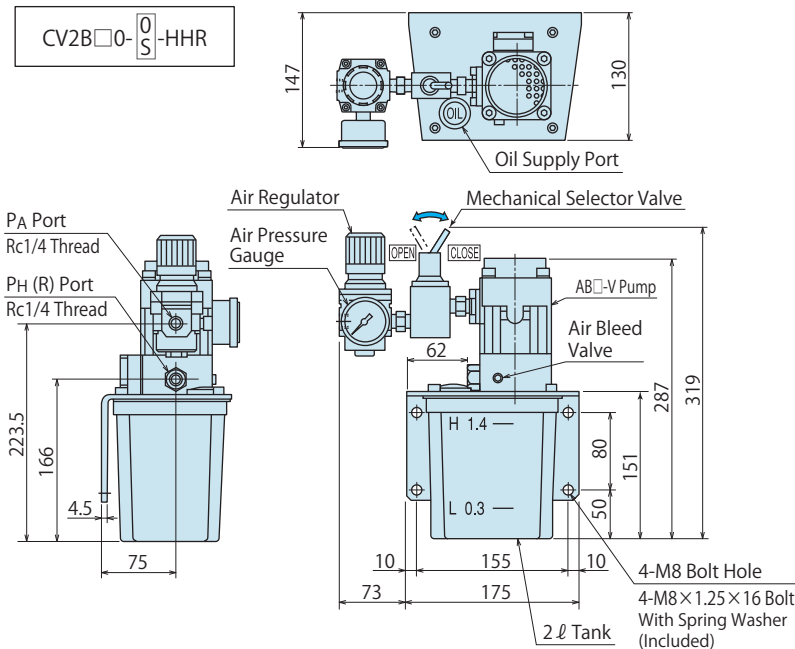

CV2B□0-□-HHR : Circuit Symbol

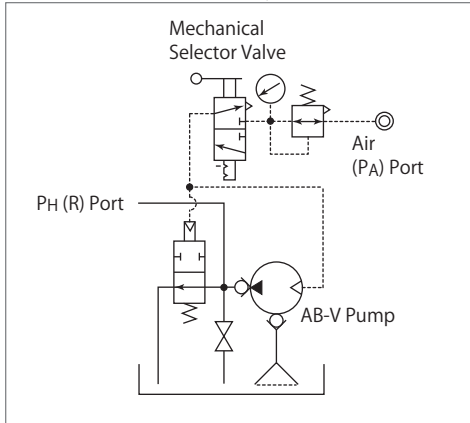

Note :
1. Please contact us for other specifications.

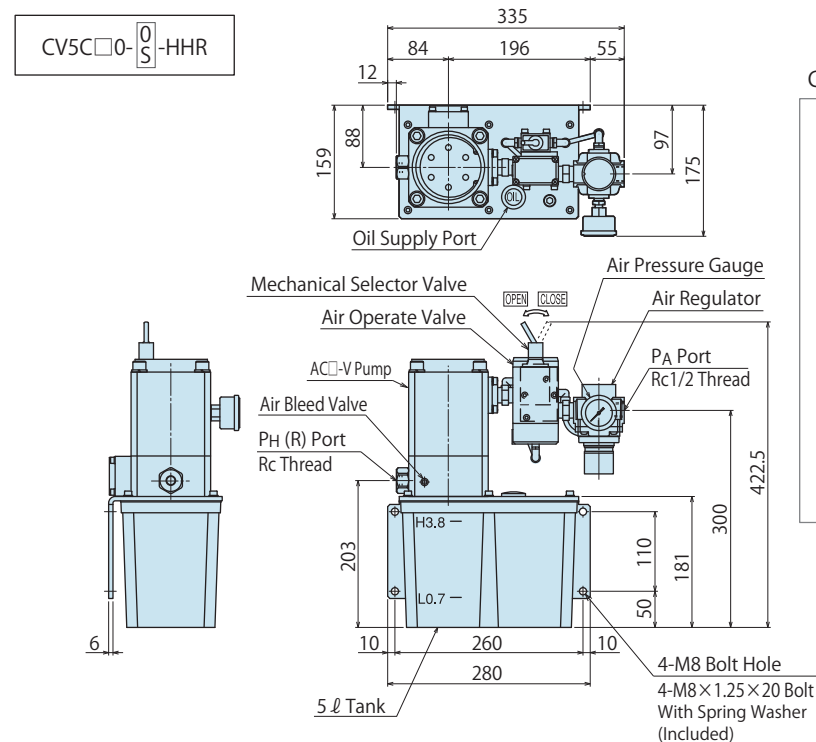

CV5C□0-□-HHR : Circuit Symbol

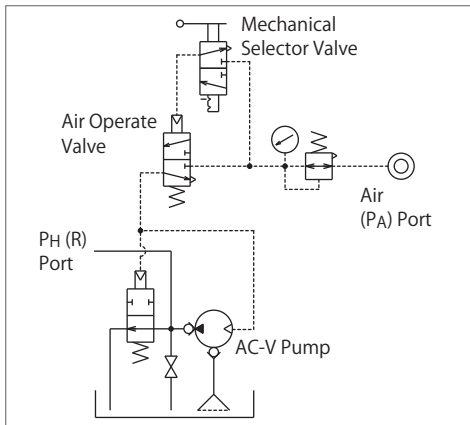

Pump Code	AC3001/AC4001	AC5001~AC9001
PH (R) Port Rc Thread	Rc3/8	Rc1/4

Note :
1. Please contact us for other specifications.

- High-Power Series
- Pneumatic Series
- Hydraulic Series
- Valve / Coupler Hydraulic Unit
- Manual Operation Accessories
- Cautions / Others

- Air Sequence Valve
- BWD
- Hydraulic Non-Leak Coupler
- BGA/BGB
- BGC/BGD
- BGP/BGS
- BBP/BBS
- BNP/BNS
- BJP/BJS
- BFP/BFS

- Auto Coupler
- JTA/JTB
- JTC/JTD
- JVA/JVB
- JVC/JVD
- JVE/JVF
- JNA/JNB
- JNC/JND
- JLP/JLS

- Rotary Joint
- JR
- Hydraulic Valve
- BK
- BEQ
- BT
- BLS/BLG
- BLB
- JSS/JS
- JKA/JKB
- BMA/BMG
- AU/AU-M
- BU
- BP/JPB
- BX
- BEP/BSP
- BH
- BC

- Air Hydraulic Unit
- CV
- CK
- CP/CPB
- CPC/CQC
- CB
- CC
- AB/AB-V
- AC/AC-V

Adding Pump Sizes 2023.3

Additional pump sizes : AB3000-□, AB5000-□, and AB6000-□

Hydraulic Unit (For Double/Single Action)

Model CK



Features

- Manual Control for Double Action/Single Action
- With Non-Leak Valve (Hydraulic pressure is held, even after air supply is cut off.)
- Portable

Model No. Indication

CK 3 B4 1 - NN - 0

1
2
3
4
5

1 Tank Capacity

3 : 3 ℓ (Actual Amount for Use 1.4 ℓ)

4 Circuit Symbol

NN : Double Action 1 Circuit (Mechanical Valve at the Position of 3, 1 Piece)
A : Single Action 1 Circuit (Mechanical Valve at the Position of 2, 1 Piece)
AA : Single Action 2 Circuit (Mechanical Valve at the Position of 2, 2 Pieces)

2 Pump Part Number (Pump Pressure Code)

B3 : AB3000-□
B4 : AB4000-□
B5 : AB5000-□
B6 : AB6000-□
B7 : AB7000-□

5 Fluid Code

0 : General Hydraulic Oil (See Hydraulic Fluid List P.1355)
S : Silicon Oil
G : Water-Glycol

※ Contact us for fluids other than those described above.

3 Design No.

1 : Revision Number

Note:

1. Offering options with handle or with air filter.
Please contact us for further information. Please note that the handle and air filter as option are not available together.

Specifications

Model No.	CK3B41-□-□	CK3B71-□-□
Pump Part Number	AB4000-□	AB7000-□
Non-Leak Valve Part Number	BA2011-0	BA5011-0
Discharge Hydraulic Pressure *1 MPa	3.9 ~ 7.0	15.5 ~ 27.0
Air Consumption Nm ³ /min	0.4	
Tank Capacity ℓ	3 ℓ (Actual Amount for Use 1.4 ℓ)	
Operating Temperature °C	0 ~ 70	
Usable Fluid	Depends on the Fluid Code (Model No. Indication)	

Notes : ※ 1. Discharge hydraulic pressure indicates when air pressure range is between 0.3 ~ 0.5MPa.

- Please refer to the AB pump performance curve for the calculation formula and the volume of discharge hydraulic pressure (P.1305).

External Dimensions / Circuit Symbol : Double Action 1 Circuit CK3□1-NN-□

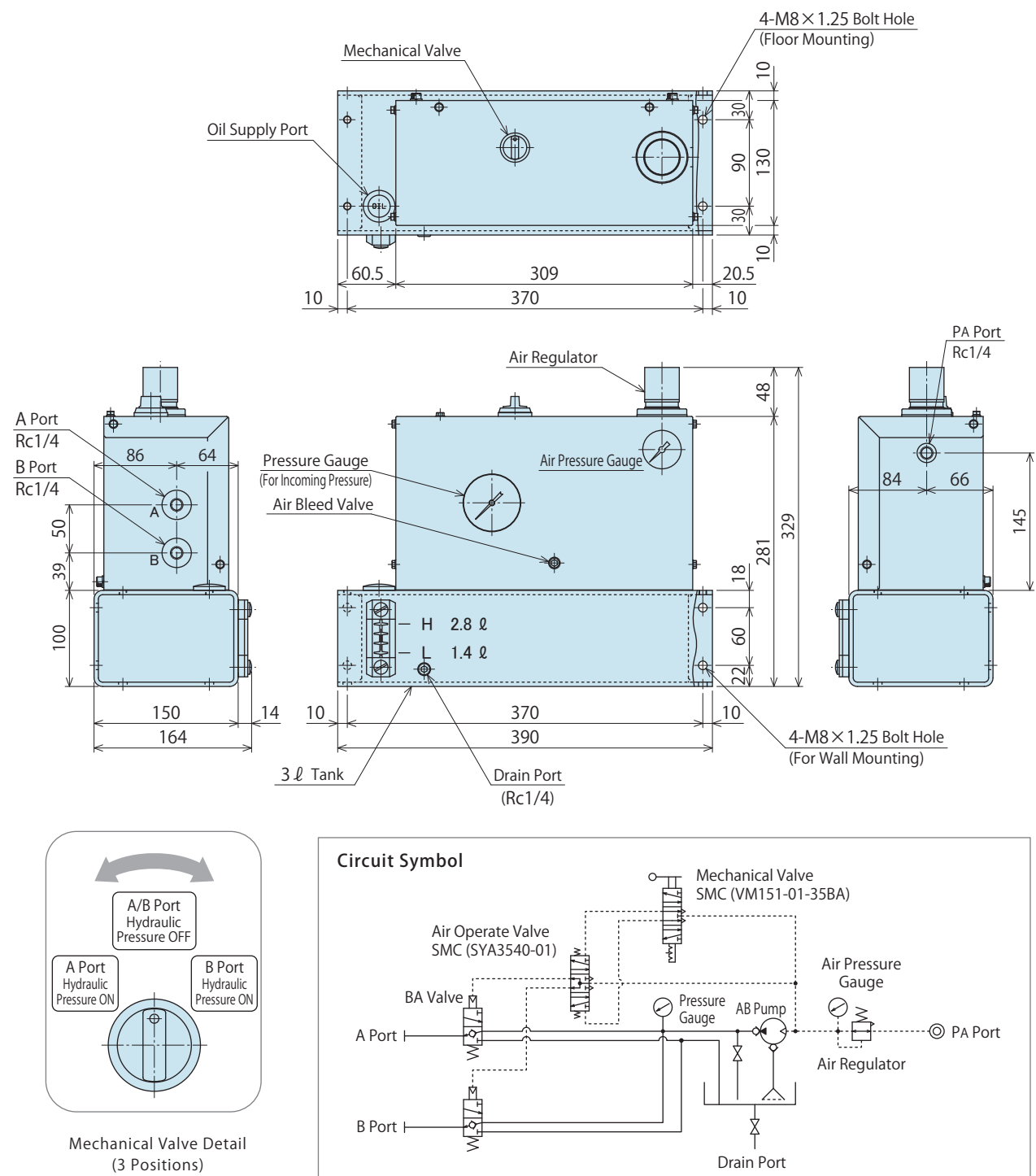

High-Power Series
Pneumatic Series
Hydraulic Series
Valve / Coupler Hydraulic Unit
Manual Operation Accessories
Cautions / Others

Air Sequence Valve
BWD
Hydraulic Non-Leak Coupler
BGA/BGB
BGC/BGD
BGP/BGS
BBP/BBS
BNP/BNS
BJP/BS
BFP/BFS

Auto Coupler
JTA/JTB
JTC/JTD
JVA/JVB
JVC/JVD
JVE/JVF
JNA/JNB
JNC/JND
JLP/JLS

Rotary Joint
JR

Hydraulic Valve
BK
BEQ
BT
BLS/BLG
BLB
JSS/JS
JKA/JKB
BMA/BMG
AU/AU-M
BU
BP/JPB
BX
BEP/BSP
BH
BC

Air Hydraulic Unit
CV
CK
CP/CPB
CPC/CQC
CB
CC
AB/AB-V
AC/AC-V

External Dimensions / Circuit Symbol : Single Action 1 Circuit CK3□1-A-□

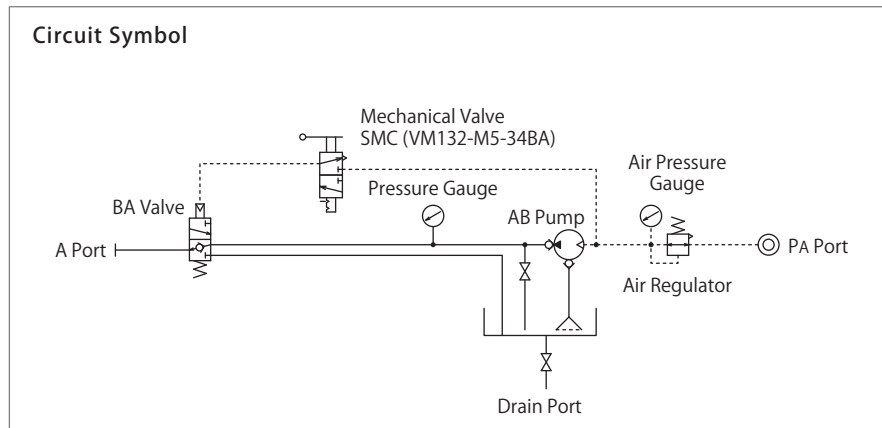
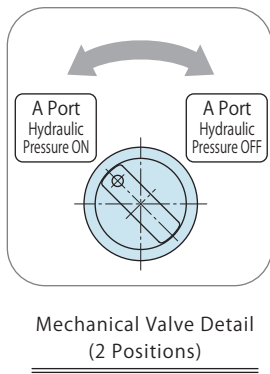
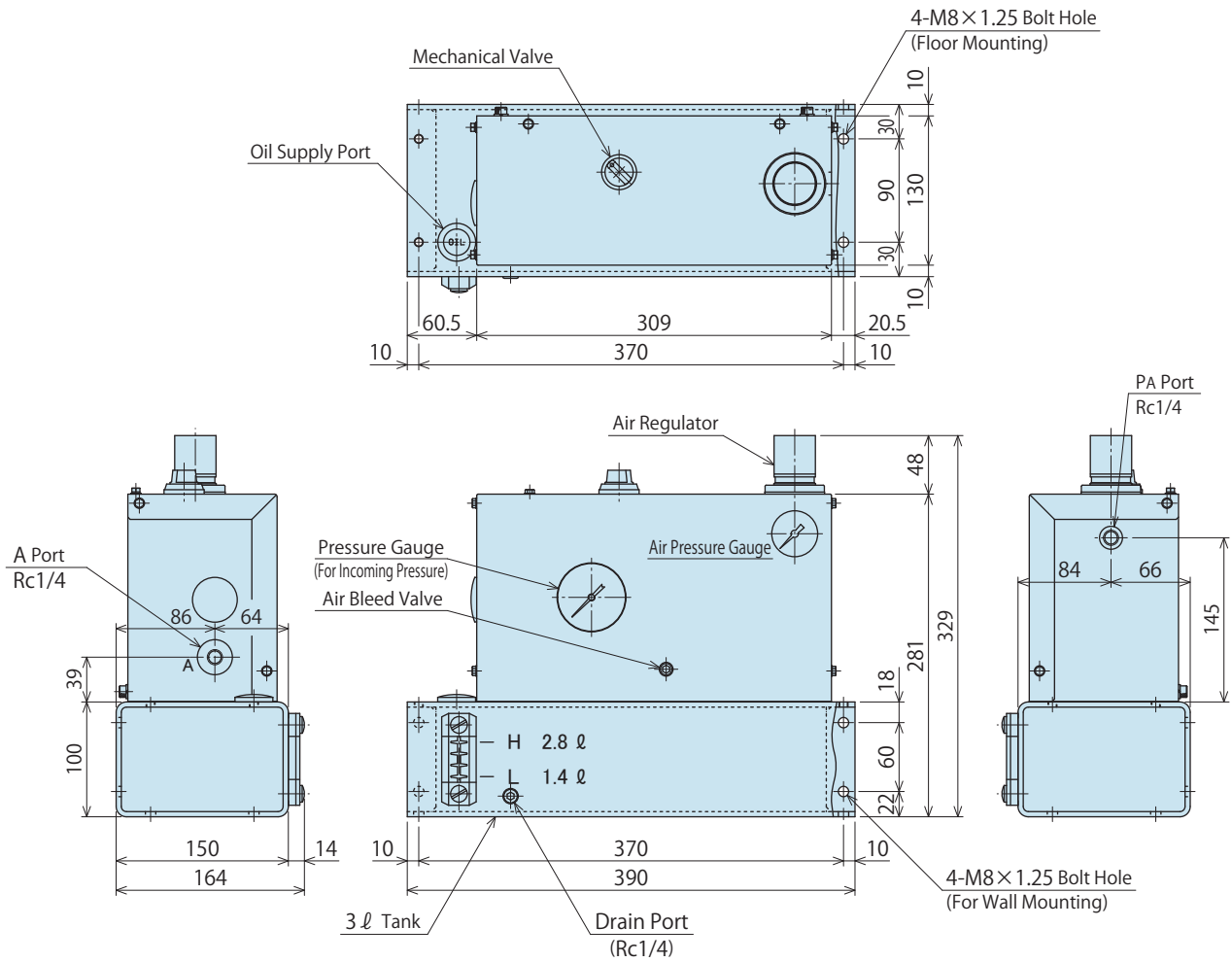

External Dimensions / Circuit Symbol : Single Action 2 Circuits CK3□1-AA-□

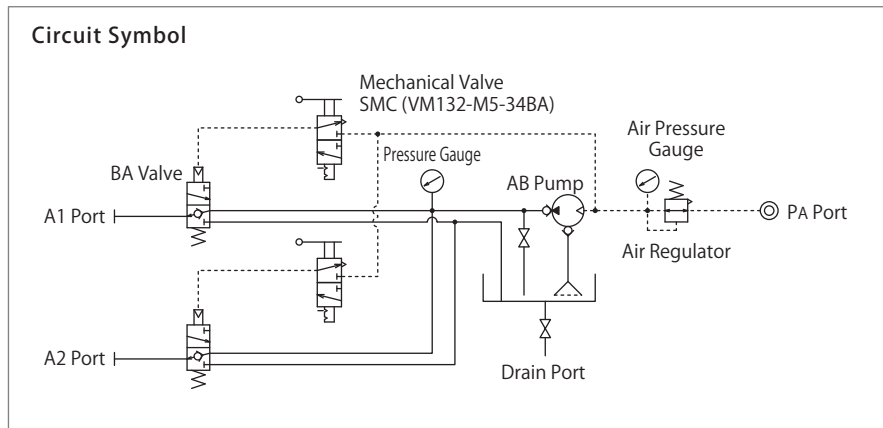
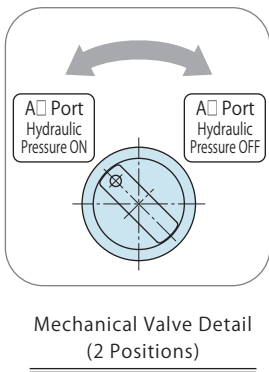
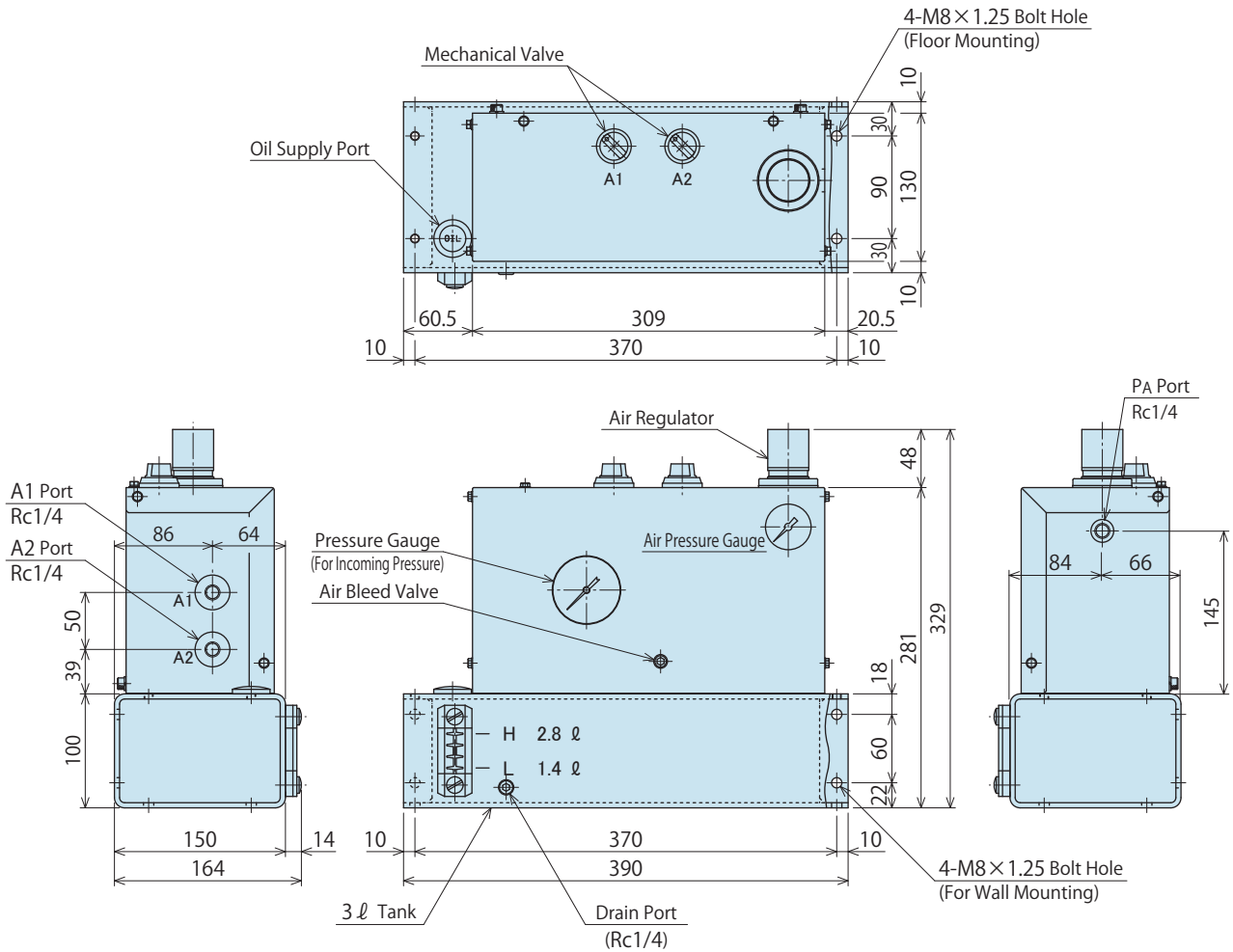

- High-Power Series
- Pneumatic Series
- Hydraulic Series
- Valve / Coupler Hydraulic Unit**
- Manual Operation Accessories
- Cautions / Others

- Air Sequence Valve
- BWD
- Hydraulic Non-Leak Coupler
- BGA/BGB
 - BGC/BGD
 - BGP/BGS
 - BBP/BBS
 - BNP/BNS
 - BJP/BS
 - BFP/BFS
- Auto Coupler
- JTA/JTB
 - JTC/JTD
 - JVA/JVB
 - JVC/JVD
 - JVE/JVF
 - JNA/JNB
 - JNC/JND
 - JLP/JLS

- Rotary Joint
- JR
- Hydraulic Valve
- BK
 - BEQ
 - BT
 - BLS/BLG
 - BLB
 - JSS/JS
 - JKA/JKB
 - BMA/BMG
 - AU/AU-M
 - BU
 - BP/JPB
 - BX
 - BEP/BSP
 - BH
 - BC

- Air Hydraulic Unit
- CV
 - CK**
 - CP/CPB
 - CPC/CQC
 - CB
 - CC
 - AB/AB-V
 - AC/AC-V

Hydraulic Unit (For Double/Single Action)

Model CP



Features

- Electrical Control for Double Action/Single Action
- With Non-Leak Valve (Hydraulic pressure is held, even after air supply is cut off.)
- Compact with AB Pump Installed • Tank Capacity 2 ℓ

- Model No. Indication** [Notice of Change in Model No. Indication] : **6** Common option has been added.
When reordering a hydraulic unit including DC24V double solenoid valve, please place the order with the new model no.

CP **2** **04** **1** - **YYYY** - **5** **B** **0** - **(7.0MPa)**

1 2 3 4 5 6 7 8 9

1 Tank Capacity

- 2** : 2 ℓ (Actual Amount for Use 1.1 ℓ)
※ Please refer to Model CPB for 5 ℓ Tank.

2 Pump Model (Pump Pressure Code)

- 03** : AB3000-□ **06** : AB6000-□
04 : AB4000-□ **07** : AB7000-□
05 : AB5000-□ **08** : AB8000-□

3 Design No.

- 1** : Revision Number

4 Circuit Symbol

※ Please contact us for other circuits.

- NN** : Double Solenoid Valve Control for Double Acting Circuit
YY : Double Solenoid Valve Control for Double Acting Circuit (With JBA Pressure Switch)
A : Single Solenoid Valve Control for Single Acting Circuit
C : Single Solenoid Valve Control for Single Acting Circuit (With JBA Pressure Switch)
U : Double Solenoid Valve Control for Single Acting Circuit (With JBA Pressure Switch)

Entry Examples

- 1 Double Acting Circuit (with JBA) × 2 → **YYYY**
1 Single Solenoid Valve Single Acting Circuit × 2 → **AA**

5 Control Voltage

- 1** : AC100V (50/60Hz) **3** : AC110V (50/60Hz) **5** : **DC24V**
2 : AC200V (50/60Hz) **4** : AC220V (50/60Hz)

6 Common

Please specify only when selecting both **4** Double Solenoid Valve and **5** DC24V. Specifications other than the above will be indicated with **Blank**.

- B** : (−) Minus Common
A : (+) Plus Common

※ Products before the change of the Model No. Indication which is without this symbol are equivalent to **B**: Minus Common.
Ex. : CP2041-NN-50-(7.0MPa) is equivalent to CP2041-NN-5**B**0-(7.0MPa).
However, when **8** Option : **C** is selected, model no. will be different. In that case, please contact us.

7 Fluid Code

- 0** : General Hydraulic Oil (See Hydraulic Fluid List on P.1355)
S : Silicon Oil
G : Water·Glycol (Iron Tank)
※ Contact us for fluids other than those described above.

8 Option

Blank : Standard

- D** : Auto-Drain Filter Regulator
F : Manual-Drain Filter Regulator
G : With Primary Pressure Gauge
H : With Piping Block on the Left
K : With Pressure Gauge for Each Circuit (with Primary Pressure Gauge)
KK : With Pressure Gauge for Each Circuit (without Primary Pressure Gauge)
L : With Pressure Switch Light
N : Piping Port NPT Thread, Pressure Gauge in both PSI / MPa Specification sheet and other documents are also in inches.
P : Pressure Gauge in both PSI / MPa
Q : With Oil Level Switch (ON when oil level drops.)
Q1 : With Oil Level Switch (OFF when oil level drops.)
T : Iron Tank

※ Contact us for non-standard specifications and dimensions of options.
※ When reordering products with Option symbol **C** : Plus Common, the model no. will be changed. In that case, please contact us.

9 Operating Pressure

Please indicate operating pressure with a proper unit symbol.

- Entry Examples At 5.5MPa → **(5.5MPa)**
 At 25MPa → **(25.0MPa)**
 At 700PSI → **(700PSI)**

Specifications

Model No.	CP2031	CP2041	CP2051	CP2061	CP2071	CP2081
Pump Part Number	AB3000-□	AB4000-□	AB5000-□	AB6000-□	AB7000-□	AB8000-□
Non-Leak Valve Part Number	BA2011-0	BA2011-0	BA5011-0	BA5011-0	BA5011-0	BA5011-0
Discharge Hydraulic Pressure ※1 MPa	2.5 ~ 4.3	3.9 ~ 7.0	6.0 ~ 11.0	10.0 ~ 17.5	15.5 ~ 27.0	25.0 ~ 30.0
Air Consumption Nm ³ /min	0.4					
Tank Capacity ℓ	2:2ℓ (Actual Amount for Use 1.1ℓ)					
Control Voltage	Depends on the Control Voltage (Model No. Indication)					
Operating Temperature °C	0 ~ 70					
Usable Fluid	Depends on the Fluid Code (Model No. Indication)					
Operation Frequency	Pump Operation Time : less than 500 hours/year (2 hrs/day) ※Actual Discharge Time					
Pressure Switch Part Number (Pressure Increase Detection) ※2	JBA0700-0G -Z0020G	JBA0700-0G	JBA0700-0G	JBA2700-0G	JBA2700-0G	JBA2700-0G
Air Solenoid Valve	Single Solenoid Valve: VO307-□G1 / Double Solenoid Valve: SYJ5240-□G					
Suction Filter	JF1030:174μm (100 mesh)					

Notes : ※1. Discharge hydraulic pressure indicates when air pressure range is between 0.3 and 0.5MPa.

The air pressure range of AB8000-□ is between 0.3MPa and 0.36MPa due to the max. operating pressure of BA5011-0 valve.

※2. Standard setting value of pressure switch should be 70% of the operating pressure.

- Please refer to the AB pump performance curve for the calculation formula and the volume of discharge hydraulic pressure (P.1305).
- If hydraulic oil having viscosity higher than the shown, activating time increases.
- In case of a low ambient temperature, action time increases because of high viscosity of hydraulic oil.
- When air contains a large amount of moisture, or air piping is located at the end, always install an automatic drain air filter.
- When installing a pressure gauge to a hydraulic circuit, install a damper or use an oil filled (glycerin) pressure gauge to prevent damage to the pressure gauge caused by pressure surging.
- Provide an enough space at the bottom of the unit to compensate for hydraulic oil change. (Tank cleaning and suction strainer tightening become easier.)

Circuit Symbol/Circuit Reference ※Please contact us for other circuits.

Circuit Symbol	Circuit (Reference)	Number of Circuits	BA Valve Number of Connection	Air Solenoid Valve	Pressure Switch
A	Single-Acting Actuator Circuit	1	1	Single Solenoid Valve	—
C		1	1	Single Solenoid Valve	○
CC		2	2	Single Solenoid Valve	○
U		1	1	Double Solenoid Valve	○
UU		2	2	Double Solenoid Valve	○
NN	Double-Acting Actuator Circuit	1	2	Double Solenoid Valve	—
YY		1	2	Double Solenoid Valve	○
YYYY		2	4	Double Solenoid Valve	○

A Single Action 1 Circuit

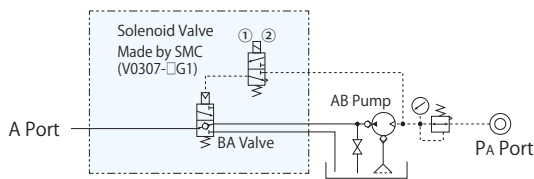

C Single Action 1 Circuit (With Pressure Switch)

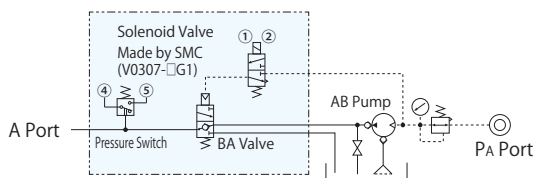

UU Single Action 2 Circuit (With Pressure Switch)

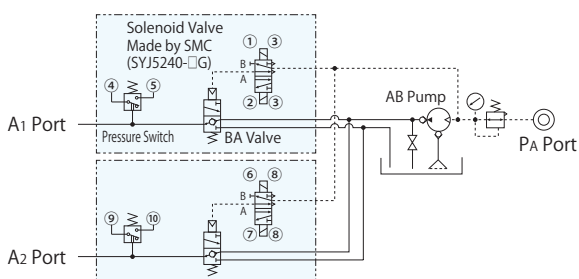

NN Double Action 1 Circuit

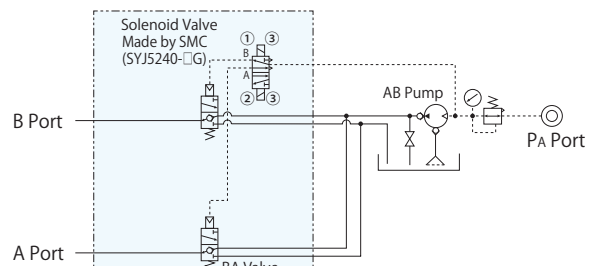

YY Double Action 1 Circuit (With Pressure Switch)

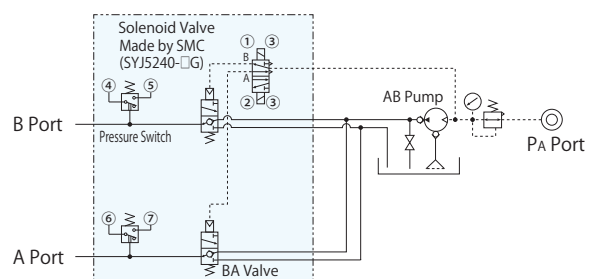

- High-Power Series
- Pneumatic Series
- Hydraulic Series
- Valve / Coupler Hydraulic Unit
- Manual Operation Accessories
- Cautions / Others

Air Sequence Valve

BWD

Hydraulic Non-Leak Coupler

BGA/BGB
BGC/BGD
BGP/BGS
BBP/BBS
BNP/BNS
BJP/BJS
BFP/BFS

Auto Coupler

JTA/JTB
JTC/JTD
JVA/JVB
JVC/JVD
JVE/JVF
JNA/JNB
JNC/JND
JLP/JLS

Rotary Joint

JR

Hydraulic Valve

BK
BEQ
BT
BLS/BLG
BLB
JSS/JS
JKA/JKB
BMA/BMG
AU/AU-M
BU
BP/JPB
BX
BEP/BSP
BH
BC

Air Hydraulic Unit

CV
CK
CP/CPB
CPC/CQC
CB
CC
AB/AB-V
AC/AC-V

External Dimensions

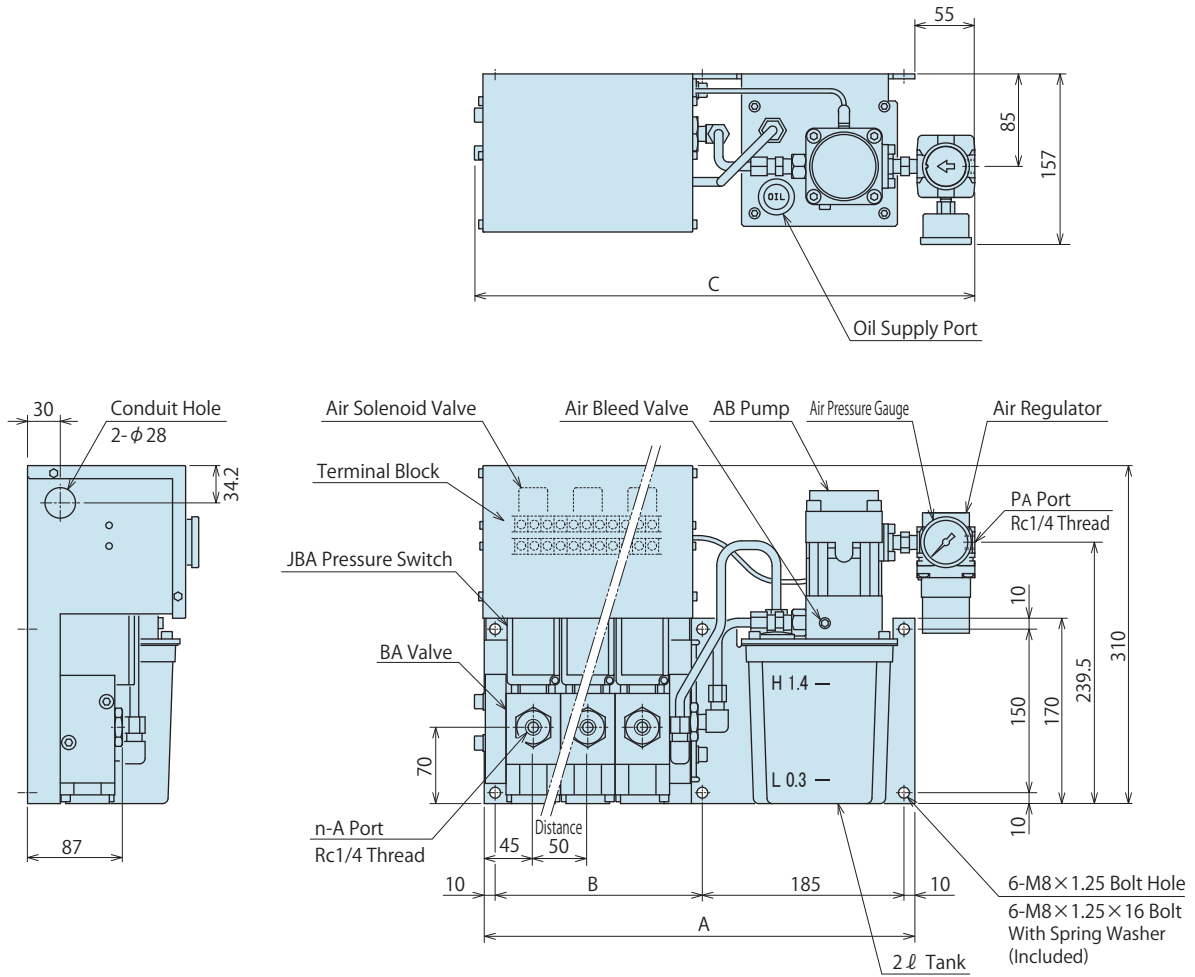

BA Valve Number of Connection	1 Connection	2 Connections	3 Connections	4 Connections
A	295	345	395	445
B	90	140	190	240
C	359	409	459	510
Weight	kg 13	15	18	20

Notes :

1. Contact us for external dimensions in case of **7** Fluid Code : **G** (Water — Glycol).
2. Contact us for external dimensions in case of options other than **8** : Standard.

MEMO

 High-Power
Series

Pneumatic Series

Hydraulic Series

**Valve / Coupler
Hydraulic Unit**

 Manual Operation
Accessories

Cautions / Others

 Air
Sequence Valve

BWD

 Hydraulic
Non-Leak Coupler

BGA/BGB

BGC/BGD

BGP/BGS

BBP/BBS

BNP/BNS

BJP/BJS

BFP/BFS

Auto Coupler

JTA/JTB

JTC/JTD

JVA/JVB

JVC/JVD

JVE/JVF

JNA/JNB

JNC/JND

JLP/JLS

Rotary Joint

JR

Hydraulic Valve

BK

BEQ

BT

BLS/BLG

BLB

JSS/JS

JKA/JKB

BMA/BMG

AU/AU-M

BU

BP/JPB

BX

BEP/BSP

BH

BC

**Air
Hydraulic Unit**

CV

CK

CP/CPB

CPC/CQC

CB

CC

AB/AB-V

AC/AC-V

Hydraulic Unit (For Double/Single Action)

Model CPB

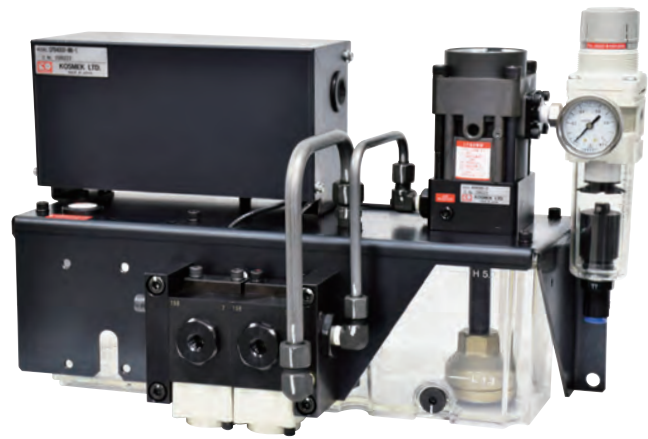

Features

- Electrical Control for Double Action/Single Action
- With Non-Leak Valve (Hydraulic pressure is held, even after air supply is cut off.)
- Compact with AB Pump Installed • Tank Capacity 5 ℓ

Model No. Indication

[Notice of Change in Model No. Indication] : **7** Common option has been added.
When reordering a hydraulic unit including DC24V double solenoid valve, please place the order with the new model no.

C P B 4 0 0 0 - 2YY - 5 **7** **8** **(7.0MPa)**

1 2 3 4 5 6 7 8 9

1 Tank Capacity

P : 5 ℓ (Actual Amount for Use 3.7 ℓ)

※ Please refer to Model CP for 2 ℓ Tank.

2 Pump Model (Pump Pressure Code)

3 : AB3000-□ **6** : AB6000-□
4 : AB4000-□ **7** : AB7000-□
5 : AB5000-□ **8** : AB8000-□

3 Fluid Code ※ Contact us for fluids other than those described below.

0 : General Hydraulic Oil (See Hydraulic Fluid List on P.1355)
S : Silicon Oil
G : Water·Glycol (Iron Tank)
F : Fatty Acid Ester

4 Design No.

0 : Revision Number

5 Circuit Symbol (Indicate with the number of circuits and circuit symbol.)

NN : Double Solenoid Valve Control for Double Acting Circuit
YY : Double Solenoid Valve Control for Double Acting Circuit
 (With JBA Pressure Switch)
E : Single Solenoid Valve Control for Single Acting Circuit
G : Single Solenoid Valve Control for Single Acting Circuit
 (With JBA Pressure Switch)
U : Double Solenoid Valve Control for Single Acting Circuit
 (With JBA Pressure Switch)

Entry Examples

1 Double Acting Circuit (with JBA)×2 → **2YY**

1 Single Solenoid Valve Single Acting Circuit×2 → **2E**

※ Please contact us for other circuits.

6 Control Voltage

1 : AC100V (50/60Hz) **4** : AC220V (50/60Hz)
2 : AC200V (50/60Hz) **5** : DC 24V
3 : AC110V (50/60Hz)

Please specify only when selecting both
5 Double Solenoid Valve and **6** 5:DC24V.
 Specifications other than the above will be
 indicated with **Blank**.

7 Common

B : (–) Minus Common

A : (+) Plus Common

※ Products before the change of the Model No. Indication which is
 without this symbol are equivalent to **B**: Minus Common.
 Ex. : CPB4000-2YY-5-(7.0MPa) is equivalent to CPB4000-2YY-5**B**-(7.0MPa).
 However, when **8** Option : **C** is selected, model no. will be different.
 In that case, please contact us.

8 Option

Blank : Standard

D : Digital Pressure Sensor

E : Without Filter Regulator

F : Manual-Drain Filter Regulator

G : With Primary Pressure Gauge

H : With Piping Block on the Left

J : With Air Regulator

K0 : With Pressure Gauge for Each Circuit (without Primary Pressure Gauge)

K1 : With Color Displayed Pressure Gauge for Each Circuit (without Primary Pressure Gauge)

KG0 : With Pressure Gauge for Each Circuit (with Primary Pressure Gauge)

KG1 : With Color Displayed Pressure Gauge for Each Circuit (with Primary Pressure Gauge)

L : With Pressure Switch Light

N : Piping Port NPT Thread, Pressure Gauge in both PSI / MPa
 Specification sheet and other documents are also in inches.

P : Pressure Gauge in both PSI / MPa

Q0 : With Oil Level Switch (ON when oil level drops.)

Q1 : With Oil Level Switch (OFF when oil level drops.)

T : Iron Tank

※ Contact us for non-standard specifications and dimensions of options.

※ When reordering products with Option symbol **C** : Plus Common,
 the model no. will be changed. In that case, please contact us.

9 Operating Pressure

Please indicate operating pressure with a proper unit symbol.

Entry Examples At 5.5MPa → **(5.5MPa)**
 At 25MPa → **(25.0MPa)**
 At 700PSI → **(700PSI)**

Specifications

Model No.	CPB30□0	CPB40□0	CPB50□0	CPB60□0	CPB70□0	CPB80□0
Pump Part Number	AB3000-□	AB4000-□	AB5000-□	AB6000-□	AB7000-□	AB8000-□
Non-Leak Valve Part Number	BA2011-0	BA2011-0	BA5011-0	BA5011-0	BA5011-0	BA5011-0
Discharge Hydraulic Pressure ※1 MPa	2.5 ~ 4.3	3.9 ~ 7.0	6.0 ~ 11.0	10.0 ~ 17.5	15.5 ~ 27.0	25.0 ~ 30.0
Air Consumption Nm ³ /min	0.4					
Tank Capacity ℓ	P:5ℓ (Actual Amount for Use 3.7ℓ)					
Control Voltage	Depends on the Control Voltage (Model No. Indication)					
Operating Temperature °C	0 ~ 70					
Usable Fluid	Depends on the Fluid Code (Model No. Indication)					
Operation Frequency	Pump Operation Time : less than 500 hours/year (2 hrs/day) ※Actual Discharge Time					
Pressure Switch Part Number (Pressure Increase Detection) ※2	JBA0700-0G -Z0020G	JBA0700-0G	JBA0700-0G	JBA2700-0G	JBA2700-0G	JBA2700-0G
Air Solenoid Valve	Single Solenoid Valve: SYJ3140-□G / Double Solenoid Valve : SYJ3240-□G					
Suction Filter	JF1030: 174μm (100 mesh)					

Notes : ※1. Discharge hydraulic pressure indicates when air pressure range is between 0.3 and 0.5MPa.

The air pressure range of AB8000-□ is between 0.3MPa and 0.36MPa due to the max. operating pressure of BA5011-0 valve.

※2. Standard setting value of pressure switch should be 70% of the operating pressure.

- Please refer to the AB pump performance curve for the calculation formula and the volume of discharge hydraulic pressure (P.1305).
- If hydraulic oil having viscosity higher than the shown, activating time increases.
- In case of a low ambient temperature, action time increases because of high viscosity of hydraulic oil.
- When installing a pressure gauge to a hydraulic circuit, install a damper or use an oil filled (glycerin) pressure gauge to prevent damage to the pressure gauge caused by pressure surging.
- Provide an enough space at the bottom of the unit to compensate for hydraulic oil change.
(Tank cleaning and suction strainer tightening become easier.)

Circuit Symbol/Circuit Reference ※Please contact us for other circuits.

Circuit Symbol	Circuit (Reference)	Number of Circuits	BA Valve Number of Connection	Air Solenoid Valve	Pressure Switch
E	Single-Acting Actuator Circuit	1	1	Single Solenoid Valve	—
G		1	1	Single Solenoid Valve	○
2G		2	2	Single Solenoid Valve	○
U		1	1	Double Solenoid Valve	○
2U		2	2	Double Solenoid Valve	○
NN	Double-Acting Actuator Circuit	1	2	Double Solenoid Valve	—
YY		1	2	Double Solenoid Valve	○
2YY		2	4	Double Solenoid Valve	○

E Single Action 1 Circuit

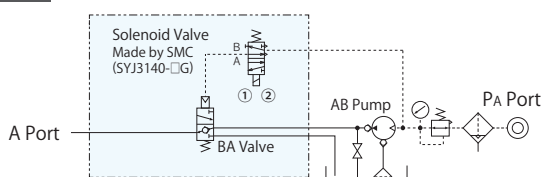

NN Double Action 1 Circuit

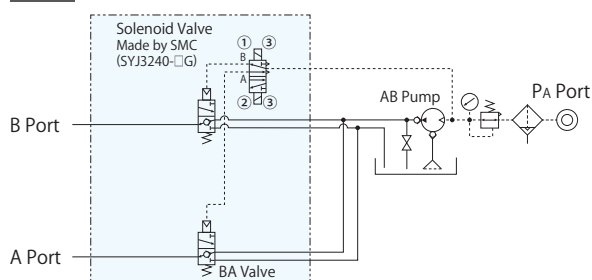

G Single Action 1 Circuit (With Pressure Switch)

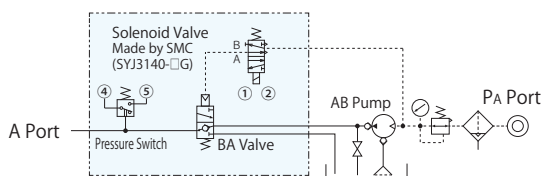

2U Single Action 2 Circuit (With Pressure Switch)

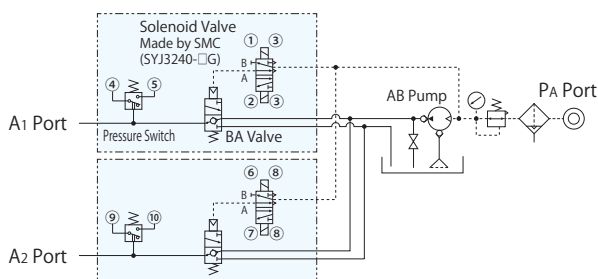

YY Double Action 1 Circuit (With Pressure Switch)

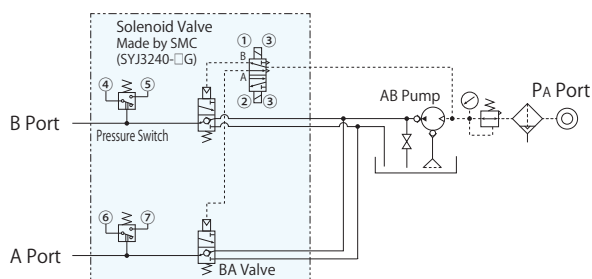

- High-Power Series
- Pneumatic Series
- Hydraulic Series
- Valve / Coupler Hydraulic Unit
- Manual Operation Accessories
- Cautions / Others

- Air Sequence Valve
 - BWD
- Hydraulic Non-Leak Coupler
 - BGA/BGB
 - BGC/BGD
 - BGP/BGS
 - BBP/BBS
 - BNP/BNS
 - BJP/BJS
 - BFP/BFS

- Auto Coupler
 - JTA/JTB
 - JTC/JTD
 - JVA/JVB
 - JVC/JVD
 - JVE/JVF
 - JNA/JNB
 - JNC/JND
 - JLP/JLS

- Rotary Joint
 - JR

- Hydraulic Valve
 - BK
 - BEQ
 - BT
 - BLS/BLG
 - BLB
 - JSS/JS
 - JKA/JKB
 - BMA/BMG
 - AU/AU-M
 - BU
 - BP/JPB
 - BX
 - BEP/BSP
 - BH
 - BC

- Air Hydraulic Unit
 - CV
 - CK
 - CP/CPB
 - CPC/CQC
 - CB
 - CC
 - AB/AB-V
 - AC/AC-V

MEMO

 High-Power
 Series

Pneumatic Series

Hydraulic Series

**Valve / Coupler
 Hydraulic Unit**

 Manual Operation
 Accessories

Cautions / Others

 Air
 Sequence Valve

BWD

 Hydraulic
 Non-Leak Coupler

BGA/BGB

BGC/BGD

BGP/BGS

BBP/BBS

BNP/BNS

BJP/BJS

BFP/BFS

Auto Coupler

JTA/JTB

JTC/JTD

JVA/JVB

JVC/JVD

JVE/JVF

JNA/JNB

JNC/JND

JLP/JLS

Rotary Joint

JR

Hydraulic Valve

BK

BEQ

BT

BLS/BLG

BLB

JSS/JS

JKA/JKB

BMA/BMG

AU/AU-M

BU

BP/JPB

BX

BEP/BSP

BH

BC

**Air
 Hydraulic Unit**

CV

CK

CP/CPB

CPC/CQC

CB

CC

AB/AB-V

AC/AC-V

Hydraulic Unit (For Double/Single Action)

Model CPC/CQC



Features

- Electrical Control for Double Action/Single Action
- With Non-Leak Valve (Hydraulic pressure is held, even after air supply is cut off.)
- Equipped with AC pump. Higher flow rate than CP/CPB unit.

- **Model No. Indication** [Notice of Change in Model No. Indication] : **7** Common option has been added.
When reordering a hydraulic unit including DC24V double solenoid valve, please place the order with the new model no.

C P C 4 0 0 0 - 2YY - 5 - (7.0MPa)

1 2 3 4 5 6 7 8 9

1 Tank Capacity

- P** : 5 ℓ (Actual Amount for Use 3.7 ℓ)
Q : 10 ℓ (Actual Amount for Use 7 ℓ) (Iron Tank)

2 Pump Model (Pump Pressure Code)

- | | |
|---------------------|---------------------|
| 3 : AC3001-□ | 6 : AC6001-□ |
| 4 : AC4001-□ | 7 : AC7001-□ |
| 5 : AC5001-□ | 8 : AC8001-□ |

3 Fluid Code

- O** : General Hydraulic Oil (See Hydraulic Fluid List on P.1355)
S : Silicon Oil
G : Water·Glycol (Iron Tank)
F : Fatty Acid Ester

※ Contact us for fluids other than those described above.

4 Design No.

- 0** : Revision Number

5 Circuit Symbol (Indicate with the number of circuits and circuit symbol.)

- NN** : Double Solenoid Valve Control for Double Acting Circuit
YY : Double Solenoid Valve Control for Double Acting Circuit (With JBA Pressure Switch)
E : Single Solenoid Valve Control for Single Acting Circuit
G : Single Solenoid Valve Control for Single Acting Circuit (With JBA Pressure Switch)
U : Double Solenoid Valve Control for Single Acting Circuit (With JBA Pressure Switch)

Entry Examples

1 Double Acting Circuit (with JBA) × 2 → **2YY**

1 Single Solenoid Valve Single Acting Circuit × 2 → **2E**

※ Please contact us for other circuits.

6 Control Voltage

- | | |
|-----------------------------|-----------------------------|
| 1 : AC100V (50/60Hz) | 4 : AC220V (50/60Hz) |
| 2 : AC200V (50/60Hz) | 5 : DC 24V |
| 3 : AC110V (50/60Hz) | |

Please specify only when selecting both **5** Double Solenoid Valve and **6 5**: DC24V. Specifications other than the above will be indicated with **Blank**.

7 Common

B : (−) Minus Common

A : (+) Plus Common

※ Products before the change of the Model No. Indication which is without this symbol are equivalent to **B**: Minus Common.
Ex.: CPC4000-2YY-5-(7.0MPa) is equivalent to CPC4000-2YY-5B-(7.0MPa).
However, when **8** Option : **C** is selected, model no. will be different. In that case, please contact us.

8 Option

Blank : Standard

D : Digital Pressure Sensor

E : Without Filter Regulator

F : Manual-Drain Filter Regulator

G : With Primary Pressure Gauge

H : With Piping Block on the Left

J : With Air Regulator

K0 : With Pressure Gauge for Each Circuit (without Primary Pressure Gauge)

K1 : With Color Displayed Pressure Gauge for Each Circuit (without Primary Pressure Gauge)

KG0 : With Pressure Gauge for Each Circuit (with Primary Pressure Gauge)

KG1 : With Color Displayed Pressure Gauge for Each Circuit (with Primary Pressure Gauge)

L : With Pressure Switch Light

N : Piping Port NPT Thread, Pressure Gauge in both PSI / MPa
Specification sheet and other documents are also in inches.

P : Pressure Gauge in both PSI / MPa

Q0 : With Oil Level Switch (ON when oil level drops.)

Q1 : With Oil Level Switch (OFF when oil level drops.)

T : Iron Tank

※ Contact us for non-standard specifications and dimensions of options.

※ When reordering products with Option symbol **C** : Plus Common, the model no. will be changed. In that case, please contact us.

9 Operating Pressure

Please indicate operating pressure with a proper unit symbol.

Entry Examples At 5.5MPa → **(5.5MPa)**
At 25MPa → **(25.0MPa)**
At 700PSI → **(700PSI)**

Specifications

Model No.	CPC30□0 CQC30□0	CPC40□0 CQC40□0	CPC50□0 CQC50□0	CPC60□0 CQC60□0	CPC70□0 CQC70□0	CPC80□0 CQC80□0
Pump Part Number	AC3001-□	AC4001-□	AC5001-□	AC6001-□	AC7001-□	AC8001-□
Non-Leak Valve Part Number	BA2011-0	BA2011-0	BA5011-0	BA5011-0	BA5011-0	BA5011-0
Discharge Hydraulic Pressure ※1 MPa	2.5 ~ 4.2	3.6 ~ 6.6	5.8 ~ 10.6	8.9 ~ 16.3	14.4 ~ 26.4	22.6 ~ 30.0
Air Consumption Nm ³ /min	1.0					
Tank Capacity ℓ	P:5ℓ (Actual Amount for Use 3.7ℓ) / Q:10ℓ (Actual Amount for Use 7ℓ)					
Control Voltage	Depends on the Control Voltage (Model No. Indication)					
Operating Temperature °C	0 ~ 70					
Usable Fluid	Depends on the Fluid Code (Model No. Indication)					
Operation Frequency	Pump Operation Time : less than 500 hours/year (2 hrs/day) ※Actual Discharge Time					
Pressure Switch Part Number (Pressure Increase Detection) ※2	JBA0700-0G -Z0020G	JBA0700-0G	JBA0700-0G	JBA2700-0G	JBA2700-0G	JBA2700-0G
Air Solenoid Valve	Single Solenoid Valve: SYJ3140-□G / Double Solenoid Valve: SYJ3240-□G					
Suction Filter	JF1030:174μm (100 mesh)					

Notes : ※1. Discharge hydraulic pressure indicates when air pressure range is between 0.3 and 0.5MPa.

The air pressure range of AC8000-□ is between 0.3MPa and 0.38MPa due to the max. operating pressure of BA5011-0 valve.

※2. Standard setting value of pressure switch should be 70% of the operating pressure.

- Please refer to the AB pump performance curve for the calculation formula and the volume of discharge hydraulic pressure (P.1305).
- If hydraulic oil having viscosity higher than the shown, activating time increases.
- In case of a low ambient temperature, action time increases because of high viscosity of hydraulic oil.
- When installing a pressure gauge to a hydraulic circuit, install a damper or use an oil filled (glycerin) pressure gauge to prevent damage to the pressure gauge caused by pressure surging.
- Provide an enough space at the bottom of the unit to compensate for hydraulic oil change.
(Tank cleaning and suction strainer tightening become easier.)

Circuit Symbol/Circuit Reference ※Please contact us for other circuits.

Circuit Symbol	Circuit (Reference)	Number of Circuits	BA Valve Number of Connection	Air Solenoid Valve	Pressure Switch
E	Single-Acting Actuator Circuit	1	1	Single Solenoid Valve	—
G		1	1	Single Solenoid Valve	○
2G		2	2	Single Solenoid Valve	○
U		1	1	Double Solenoid Valve	○
2U		2	2	Double Solenoid Valve	○
NN	Double-Acting Actuator Circuit	1	2	Double Solenoid Valve	—
YY		1	2	Double Solenoid Valve	○
2YY		2	4	Double Solenoid Valve	○

E Single Action 1 Circuit

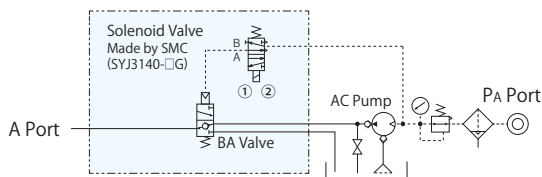

NN Double Action 1 Circuit

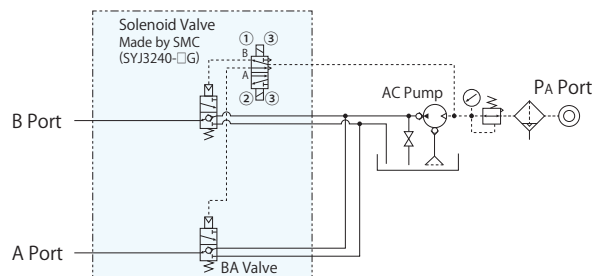

G Single Action 1 Circuit (With Pressure Switch)

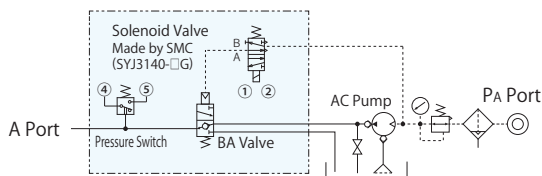

2U Single Action 2 Circuit (With Pressure Switch)

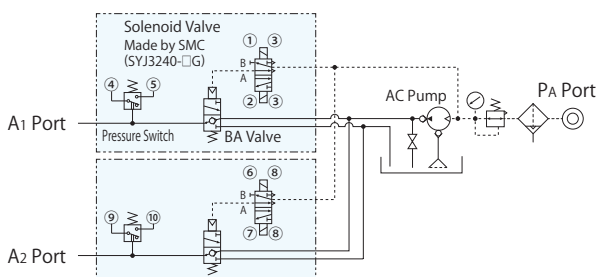

YY Double Action 1 Circuit (With Pressure Switch)

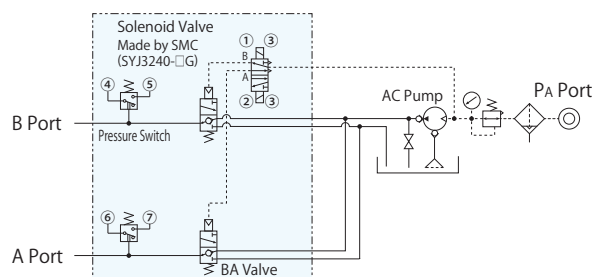

- High-Power Series
- Pneumatic Series
- Hydraulic Series
- Valve / Coupler Hydraulic Unit
- Manual Operation Accessories
- Cautions / Others

- Air Sequence Valve
 - BWD
- Hydraulic Non-Leak Coupler
 - BGA/BGB
 - BGC/BGD
 - BGP/BGS
 - BBP/BBS
 - BNP/BNS
 - BJP/BJS
 - BFP/BFS

- Auto Coupler
 - JTA/JTB
 - JTC/JTD
 - JVA/JVB
 - JVC/JVD
 - JVE/JVF
 - JNA/JNB
 - JNC/JND
 - JLP/JLS

- Rotary Joint
 - JR

- Hydraulic Valve
 - BK
 - BEQ
 - BT
 - BLS/BLG
 - BLB
 - JSS/JS
 - JKA/JKB
 - BMA/BMG
 - AU/AU-M
 - BU
 - BP/JPB
 - BX
 - BEP/BSP
 - BH
 - BC

- Air Hydraulic Unit
 - CV
 - CK
 - CP/CPB
 - CPC/CQC
 - CB
 - CC
 - AB/AB-V
 - AC/AC-V

External Dimensions : CPC

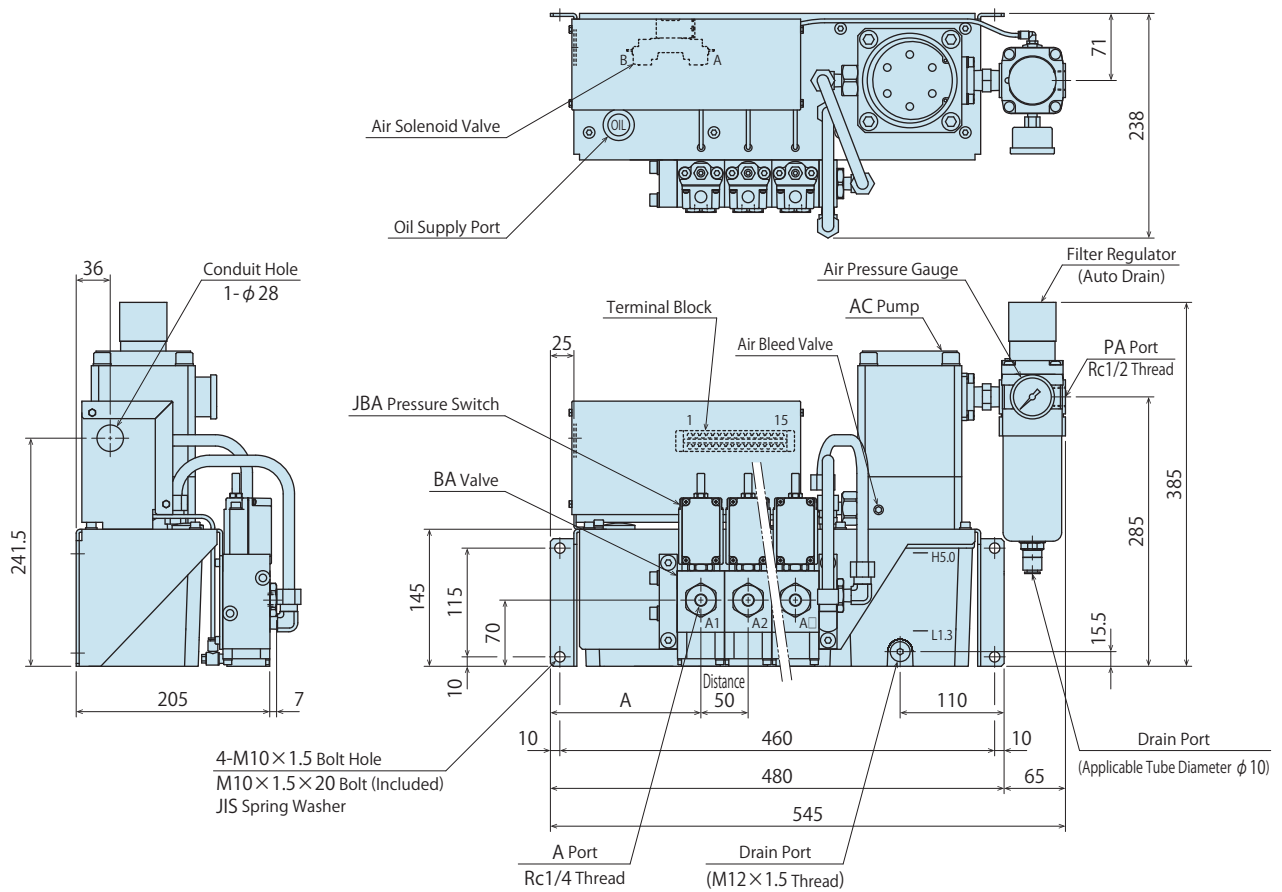

BA Valve Number of Connection	1 Connection	2 Connections	3 Connections	4 Connections
A	259	209	159	109

Notes :

1. Contact us for external dimensions in case of **3** Fluid Code : **G** (Water — Glycol).
2. Contact us for external dimensions in case of options other than **8** : Standard.
3. External dimensions for five or more circuits are different. Please contact us for further information.

External Dimensions : CQC

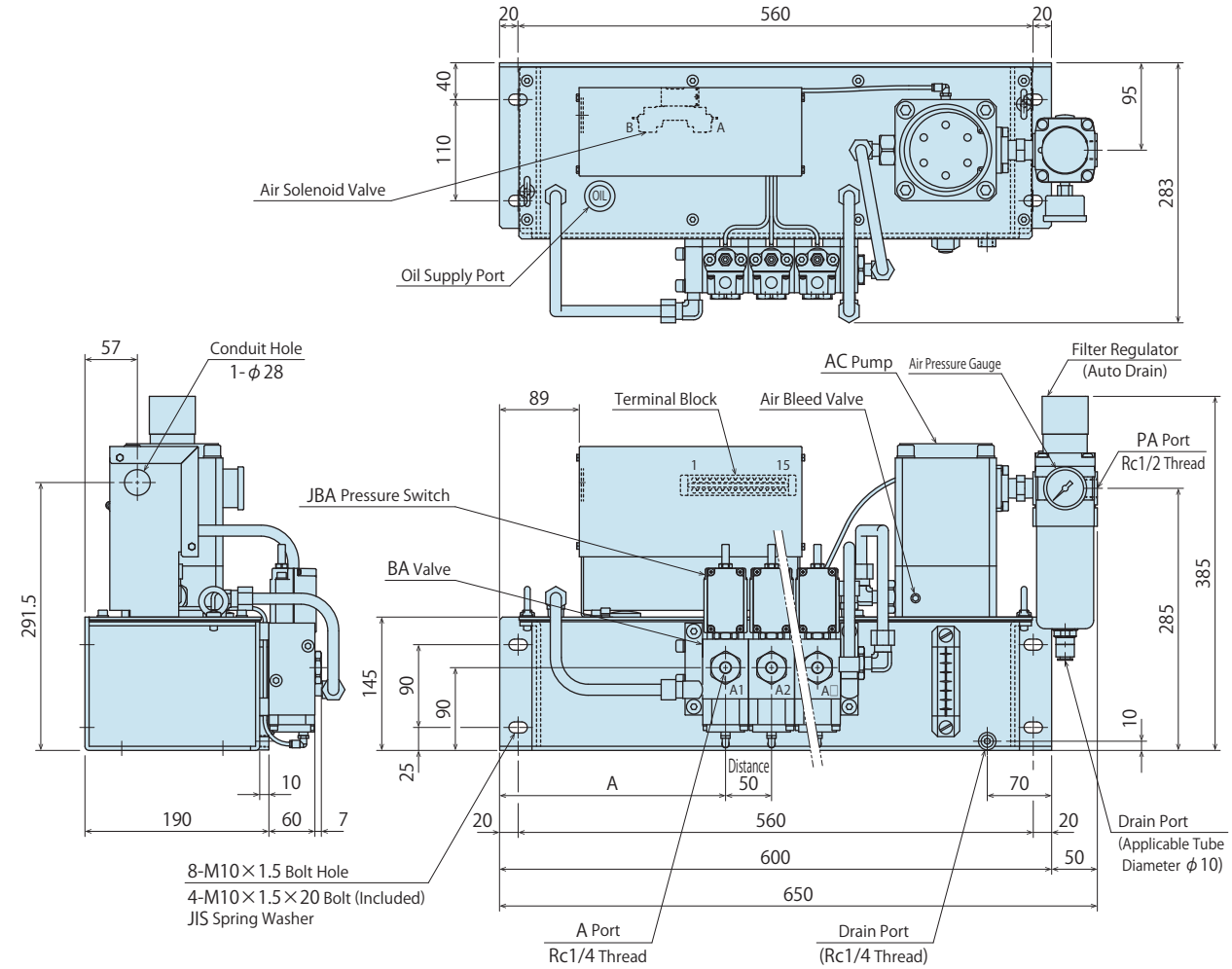

BA Valve Number of Connection	1 Connection	2 Connections	3 Connections	4 Connections
A	345.5	295.5	245.5	195.5

Notes :

- Contact us for external dimensions in case of **3** Fluid Code : **G** (Water — Glycol).
- Contact us for external dimensions in case of options other than **8** : Standard.
- External dimensions for five or more circuits are different. Please contact us for further information.

- High-Power Series
- Pneumatic Series
- Hydraulic Series
- Valve / Coupler Hydraulic Unit**
- Manual Operation Accessories
- Cautions / Others

Air Sequence Valve

- BWD

Hydraulic Non-Leak Coupler

- BGA/BGB
- BGC/BGD
- BGP/BGS
- BBP/BBS
- BNP/BNS
- BJP/BSJ
- BFP/BFS

Auto Coupler

- JTA/JTB
- JTC/JTD
- JVA/JVB
- JVC/JVD
- JVE/JVF
- JNA/JNB
- JNC/JND
- JLP/JLS

Rotary Joint

- JR

Hydraulic Valve

- BK
- BEQ
- BT
- BLS/BLG
- BLB
- JSS/JS
- JKA/JKB
- BMA/BMG
- AU/AU-M
- BU
- BP/JPB
- BX
- BEP/BSP
- BH
- BC

Air Hydraulic Unit

- CV
- CK
- CP/CPB
- CPC/CQC**
- CB
- CC
- AB/AB-V
- AC/AC-V

Pump Unit (For Double/Single Action)

Model CB



Features

- Pump Unit to use in conjunction with BC / BH Non-Leak Valve Unit
 - Compact with AB Pump Installed
- ※Please refer to P.1275, P.1277 for BC/BH non-leak valve unit.

Model No. Indication

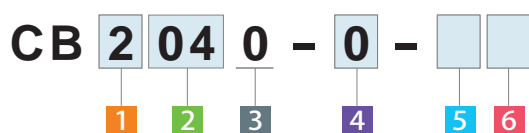

1 Tank Capacity

- 2** : 2 l (Actual Amount for Use 1.1 l)
5 : 5 l (Actual Amount for Use 3.1 l)

2 Pump Model (Pump Pressure Code)

- | | |
|----------------------|----------------------|
| 03 : AB3000-□ | 06 : AB6000-□ |
| 04 : AB4000-□ | 07 : AB7000-□ |
| 05 : AB5000-□ | 08 : AB8000-□ |

3 Design No.

- 0** : Revision Number

4 Fluid Code

- 0** : General Hydraulic Oil (See Hydraulic Fluid List on P.1355)
S : Silicon Oil
G : Water-Glycol (except AB8000) (Iron Tank)

※ Contact us for fluids other than those described above.

5 Option

- Blank** : Standard (Air Regulator)
D : Auto-Drain Filter Regulator
Q : With Oil Level Switch

6 Unit of Pressure Gauge

- Blank** : MPa (Standard)
P : PSI (Used only in the US)

Specifications

Model No.	CB□030	CB□040	CB□050	CB□060	CB□070	CB□080
Pump Part Number	AB3000-□	AB4000-□	AB5000-□	AB6000-□	AB7000-□	AB8000-□
Discharge Hydraulic Pressure ※1 ※2 MPa	2.4 ~ 4.3	3.9 ~ 7.0	6.0 ~ 11.0	10.0 ~ 17.5	15.5 ~ 27.0	25.0 ~ 43.5
Air Consumption Nm ³ /min	0.4					
Tank Capacity ℓ	2:2ℓ (Actual Amount for Use 1.1ℓ) / 5:5ℓ (Actual Amount for Use 3.1ℓ)					
Operating Temperature °C	0 ~ 70					
Usable Fluid	Depends on the Fluid Code (Model No. Indication)					
Operation Frequency	Pump Operation Time : less than 500 hours/year (2 hrs/day) ※Actual Discharge Time					
Weight kg	CB20□0 (2ℓ Tank)	6.0				
	CB50□0 (5ℓ Tank)	7.5				

Notes : ※1. Discharge hydraulic pressure indicates when air pressure range is between 0.3 and 0.5MPa.

※2. Please be careful of the operating pressure range of BH / BC unit to be used in combination.

Example : In case of using CB□080 and BH0071 together, actual operating pressure range is 25 to 30MPa.

(CB□080 range = 25 to 43.5MPa, BH0071 range = 6 to 30MPa).

1. Please refer to the AB pump performance curve for the calculation formula and the volume of discharge hydraulic pressure (P.1305).

Circuit Symbol

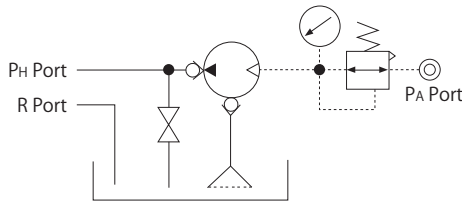

Application Example

Manual control of double-acting cylinder with BH (NN circuit).

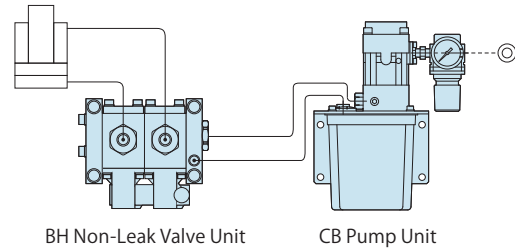

External Dimensions

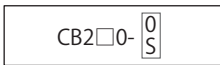

※ This drawing shows the specifications in case of :
Tank = 2ℓ, Fluid = General Hydraulic Oil or Silicon Oil,
Option = Standard.

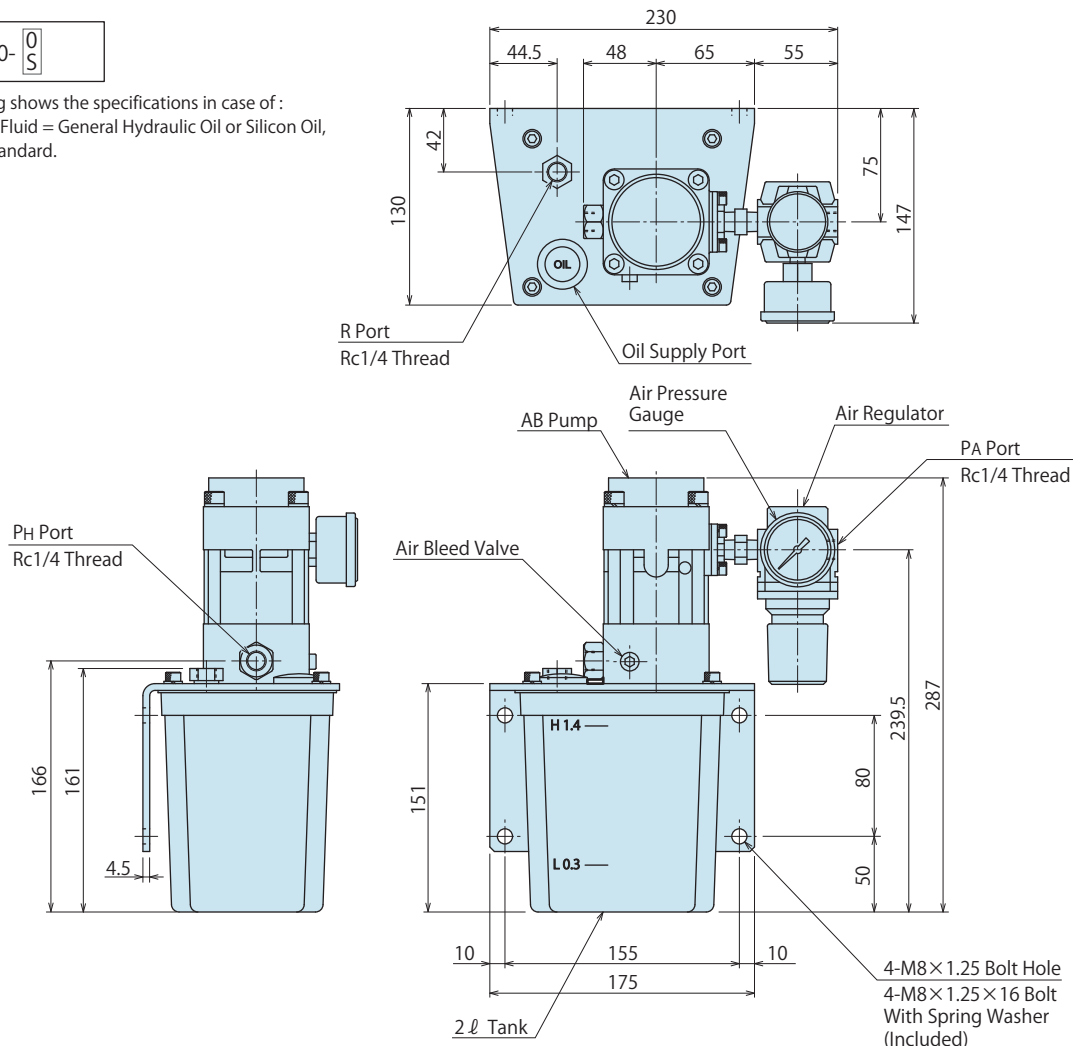

Note :

1. Please contact us for the specification (5.0ℓ tank, water-glycol, with filter regulator, level switch etc.) other than the drawing above.

High-Power Series

Pneumatic Series

Hydraulic Series

Valve / Coupler Hydraulic Unit

Manual Operation Accessories

Cautions / Others

Air Sequence Valve

BWD

Hydraulic Non-Leak Coupler

BGA/BGB

BGC/BGD

BGP/BGS

BBP/BBS

BNP/BNS

BJP/BJS

BFP/BFS

Auto Coupler

JTA/JTB

JTC/JTD

JVA/JVB

JVC/JVD

JVE/JVF

JNA/JNB

JNC/JND

JLP/JLS

Rotary Joint

JR

Hydraulic Valve

BK

BEQ

BT

BLS/BLG

BLB

JSS/JS

JKA/JKB

BMA/BMG

AU/AU-M

BU

BP/JPB

BX

BEP/BSP

BH

BC

Air Hydraulic Unit

CV

CK

CP/CPB

CPC/CQC

CB

CC

AB/AB-V

AC/AC-V

Pump Unit (For Double/Single Action)

Model CC



Features

- Pump Unit to use in conjunction with BC / BH Non-Leak Valve Unit
 - Equipped with AC pump. Higher flow rate than CB unit.
- ※Please refer to P.1275, P.1277 for BC/BH non-leak valve unit.

Model No. Indication

CC 5 04 0 - 0 - □ □

1 2 3 4 5 6

1 Tank Capacity

5 : 5 ℓ (Actual Amount for Use 3.1 ℓ)

2 Pump Model (Pump Pressure Code)

03 : AC3001-□	07 : AC7001-□
04 : AC4001-□	08 : AC8001-□
05 : AC5001-□	09 : AC9001-□
06 : AC6001-□	

3 Design No.

0 : Revision Number

4 Fluid Code

0 : General Hydraulic Oil (See Hydraulic Fluid List on P.1355)

S : Silicon Oil

G : Water-Glycol (except AC8001/AC9001) (Iron Tank)

※ Contact us for fluids other than those described above.

5 Option

Blank : Standard (Air Regulator)

D : Auto-Drain Filter Regulator

Q : With Oil Level Switch

6 Unit of Pressure Gauge

Blank : MPa (Standard)

P : PSI (Used only in the US)

Specifications

Model No.	CC5030	CC5040	CC5050	CC5060	CC5070	CC5080	CC5090
Pump Part Number	AC3001-□	AC4001-□	AC5001-□	AC6001-□	AC7001-□	AC8001-□	AC9001-□
Discharge Hydraulic Pressure ※1 ※2 MPa	2.3 ~ 4.2	3.6 ~ 6.6	5.8 ~ 10.6	8.9 ~ 16.3	14.4 ~ 26.4	22.6 ~ 41.4	35.3 ~ 64.7
Air Consumption Nm ³ /min	1.0						
Tank Capacity ℓ	5:5 ℓ (Actual Amount for Use 3.1 ℓ)						
Operating Temperature °C	0 ~ 70						
Usable Fluid	Depends on the Fluid Code (Model No. Indication)						
Operation Frequency	Pump Operation Time : less than 500 hours/year (2 hrs/day) ※Actual Discharge Time						

Notes : ※1. Discharge hydraulic pressure indicates when air pressure range is between 0.3 and 0.5MPa.

※2. Please be careful of the operating pressure range of BH / BC unit to be used in combination.

Example : In case of using CC5080 and BH0071 together, actual operating pressure range is 22.6 to 30MPa.

(CC5080 range = 22.6 to 41.4MPa, BH0071 range = 6 to 30MPa).

1. Please refer to the AC pump performance curve for the calculation formula and the volume of discharge hydraulic pressure (P.1305).

Circuit Symbol

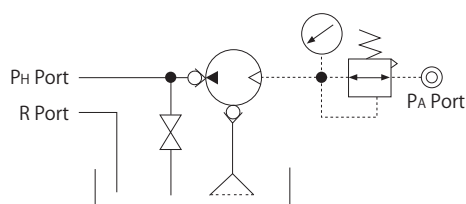

Application Example

Manual control of double-acting cylinder with BH (NN circuit).

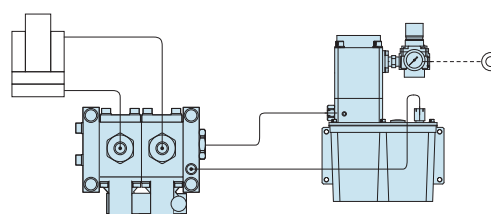

BH Non-Leak Valve Unit

CC Pump Unit

External Dimensions

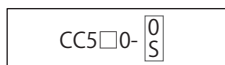

※ This drawing shows the specifications in case of :
Tank = 5 ℓ , Fluid = General Hydraulic Oil or Silicon Oil,
Option = Standard.

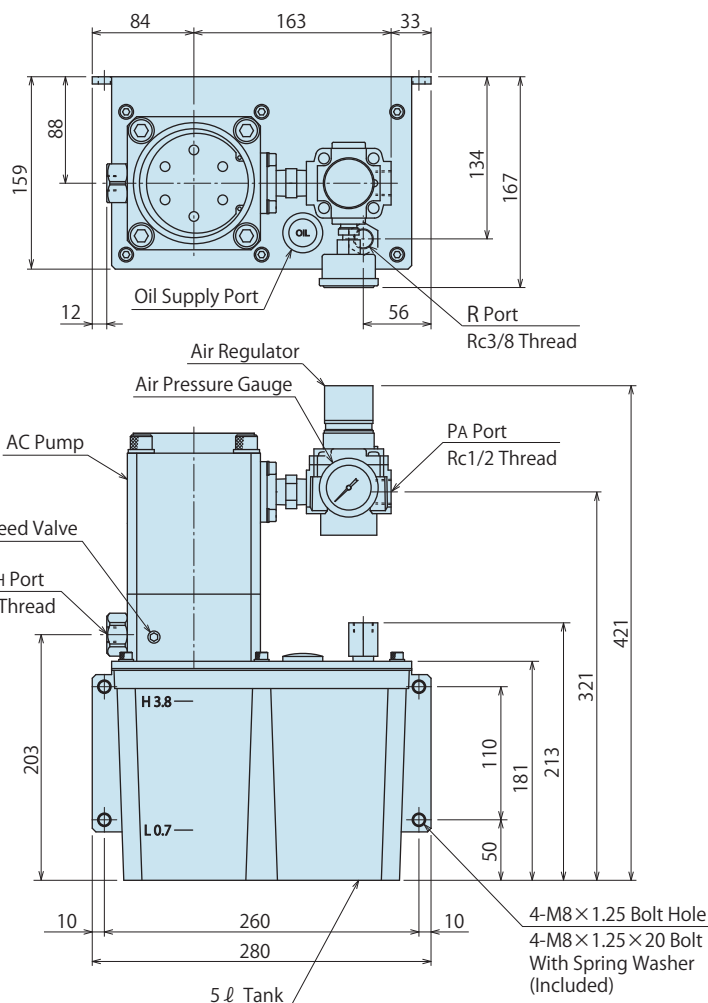

High-Power Series

Pneumatic Series

Hydraulic Series

Valve / Coupler Hydraulic Unit

Manual Operation Accessories

Cautions / Others

Air Sequence Valve

BWD

Hydraulic Non-Leak Coupler

BGA/BGB

BGC/BGD

BGP/BGS

BBP/BBS

BNP/BNS

BJP/BJS

BFP/BFS

Auto Coupler

JTA/JTB

JTC/JTD

JVA/JVB

JVC/JVD

JVE/JVF

JNA/JNB

JNC/JND

JLP/JLS

Rotary Joint

JR

Hydraulic Valve

BK

BEQ

BT

BLS/BLG

BLB

JSS/JS

JKA/JKB

BMA/BMG

AU/AU-M

BU

BP/JPB

BX

BEP/BSP

BH

BC

Air Hydraulic Unit

CV

CK

CP/CPB

CPC/CQC

CB

CC

AB/AB-V

AC/AC-V

Pump Code	AC3001/AC4001	AC5001~AC9001
S	Rc3/8	Rc1/4

Note :

1. Please contact us for the specification (water-glycol, with filter regulator, level switch etc.) other than the drawing above.

AB Pump / AC Pump (Air Driven Hydraulic Pump)

Model AB/AC



Features

- Air-driven hydraulic pump to generate high-pressure hydraulic-low pressure simply by supplying compressed air.
- Variation of total 13 different sizes and flow rates.
- Applicable to explosion proof specification because no electric motor is used.

Model No. Indication

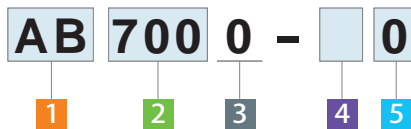

1 Pump Size

AB : AB Pump (Compact Design, Air Consumption 0.4 Nm³/min)

AC : AC Pump (High Volume of Flow, Air Consumption 1.0 Nm³/min)

2 Pressure Range ※Discharge hydraulic pressure indicates when air pressure range is between 0.3 ~ 0.5MPa.

300 : Discharge Hydraulic Pressure With AB Pump: 2.4 ~ 4.3MPa	With AC Pump: 2.3 ~ 4.2MPa
400 : Discharge Hydraulic Pressure With AB Pump: 3.9 ~ 7.0MPa	With AC Pump: 3.6 ~ 6.6MPa
500 : Discharge Hydraulic Pressure With AB Pump: 6.0 ~ 11.0MPa	With AC Pump: 5.8 ~ 10.6MPa
600 : Discharge Hydraulic Pressure With AB Pump: 10.0 ~ 17.5MPa	With AC Pump: 8.9 ~ 16.3MPa
700 : Discharge Hydraulic Pressure With AB Pump: 15.5 ~ 27.0MPa	With AC Pump: 14.4 ~ 26.4MPa
800 : Discharge Hydraulic Pressure With AB Pump: 25.0 ~ 43.5MPa	With AC Pump: 22.6 ~ 41.4MPa
900 : Discharge Hydraulic Pressure No AB Pump at this range.	With AC Pump: 35.3 ~ 64.7MPa

3 Design No. Revision Number

0 : In case of AB pump

1 : In case of AC pump

4 Circuit Symbol

Blank : Standard

V : Valve Built-In Option

5 Usable Fluid

0 : General Hydraulic Oil (See Hydraulic Fluid List on P.1355)

S : Silicon Oil

G : Water-Glycol

※ Contact us for fluids other than those described above.

Specifications

Model No.	AB3000-□□	AB4000-□□	AB5000-□□	AB6000-□□	AB7000-□□	AB8000-□□
Discharge Hydraulic Pressure ※1 MPa	2.4 ~ 4.3	3.9 ~ 7.0	6.0 ~ 11.0	10.0 ~ 17.5	15.5 ~ 27.0	25.0 ~ 43.5
Air Consumption Nm ³ /min	0.4					
Operating Air Pressure Range MPa	0.15 ~ 0.7					
Lift m	below 0.6					
Noise dB	82 ~ 85					
Usable Fluid ※2	Depends on the Fluid Code (Model No. Indication)					
Applicable Suction Filter ※3	JF1030					
Weight kg	2.4					

Model No.	AC3001-□□	AC4001-□□	AC5001-□□	AC6001-□□	AC7001-□□	AC8001-□□	AC9001-□□
Discharge Hydraulic Pressure ※1 MPa	2.3 ~ 4.2	3.6 ~ 6.6	5.8 ~ 10.6	8.9 ~ 16.3	14.4 ~ 26.4	22.6 ~ 41.4	35.3 ~ 64.7
Air Consumption Nm ³ /min	1.0						
Operating Air Pressure Range MPa	0.15 ~ 0.7						
Lift m	below 1.0						
Noise dB	82 ~ 85						
Usable Fluid ※2	Depends on the Fluid Code (Model No. Indication)						
Applicable Suction Filter ※3	JF1040			JF1030			
Weight kg	8.8						

- Notes : ※1. Discharge hydraulic pressure indicates when air pressure range is between 0.3 ~ 0.5MPa.
 ※2. For fluids other than those described in the fluid code, please contact us.
 ※3. Suction filter and suction pipe is not attached. If it is needed, please prepare separately.

Circuit Symbol

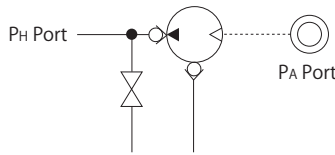

4 Circuit Symbol Blank : Standard

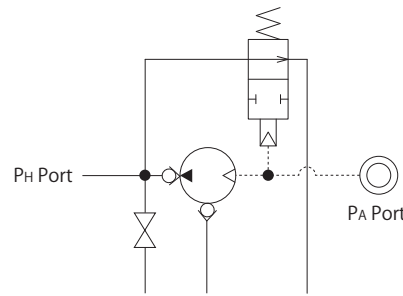

4 Circuit Symbol V : Valve Built-In Option

Action Description

Actions ① through ④ are repeated to discharge oil.
 When "Air Pressure × Piston Area" balances with "Hydraulic Pressure × Plunger Area", the piston stops automatically.

① Initial Position

② Discharge Process

③ Air Supply Switching

④ Suction Process (Air Vent)

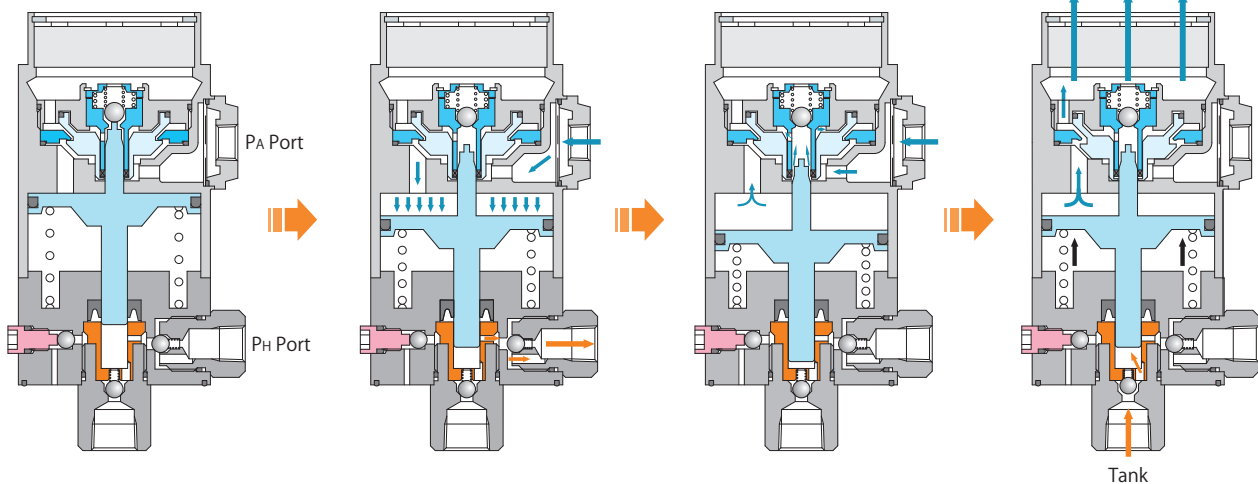

High-Power Series

Pneumatic Series

Hydraulic Series

Valve / Coupler Hydraulic Unit

Manual Operation Accessories

Cautions / Others

Air Sequence Valve

BWD

Hydraulic Non-Leak Coupler

BGA/BGB

BGC/BGD

BGP/BGS

BBP/BBS

BNP/BNS

BJP/BJS

BFP/BFS

Auto Coupler

JTA/JTB

JTC/JTD

JVA/JVB

JVC/JVD

JVE/JVF

JNA/JNB

JNC/JND

JLP/JLS

Rotary Joint

JR

Hydraulic Valve

BK

BEQ

BT

BLS/BLG

BLB

JSS/JS

JKA/JKB

BMA/BMG

AU/AU-M

BU

BP/JPB

BX

BEP/BSP

BH

BC

Air Hydraulic Unit

CV

CK

CP/CPB

CPC/CQC

CB

CC

AB/AB-V

AC/AC-V

Performance Curve

AB3000 Calculation Formula $P_H = 9.4(P_A - 0.04)$

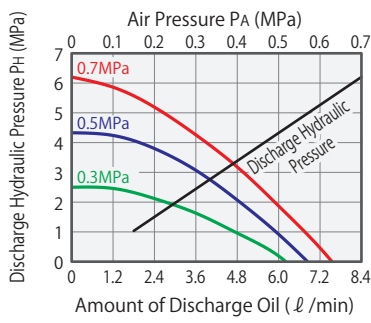

AB4000 Calculation Formula $P_H = 15(P_A - 0.04)$

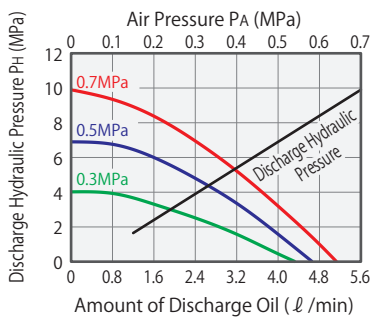

AB5000 Calculation Formula $P_H = 24(P_A - 0.04)$

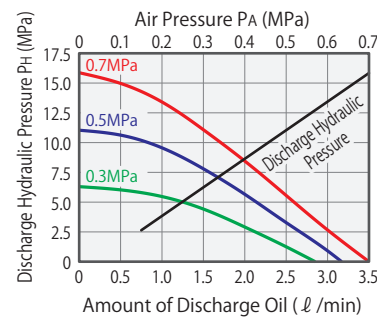

AB6000 Calculation Formula $P_H = 38(P_A - 0.04)$

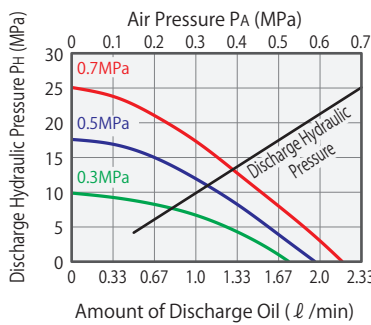

AB7000 Calculation Formula $P_H = 59(P_A - 0.04)$

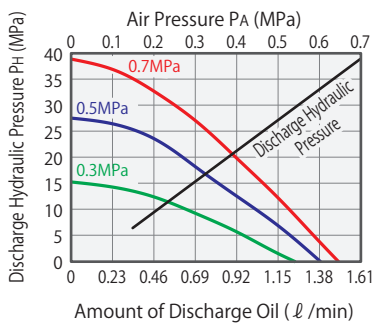

AB8000 Calculation Formula $P_H = 95(P_A - 0.04)$

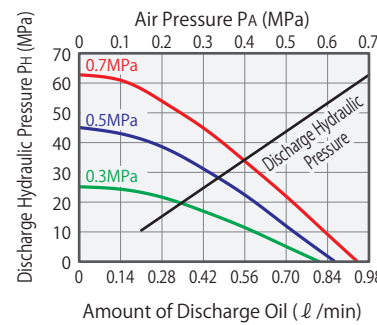

AC3001 Calculation Formula $P_H = 9.5(P_A - 0.06)$

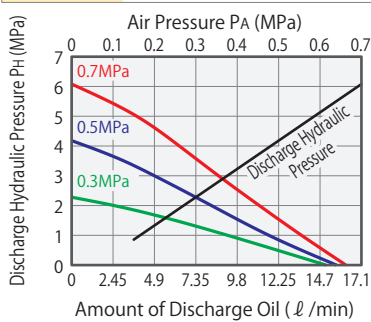

AC4001 Calculation Formula $P_H = 15(P_A - 0.06)$

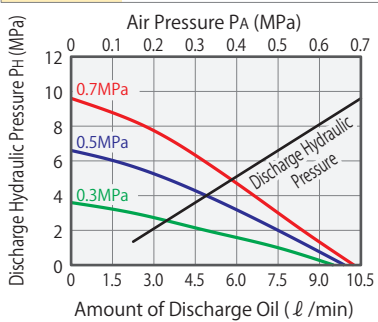

AC5001 Calculation Formula $P_H = 24(P_A - 0.06)$

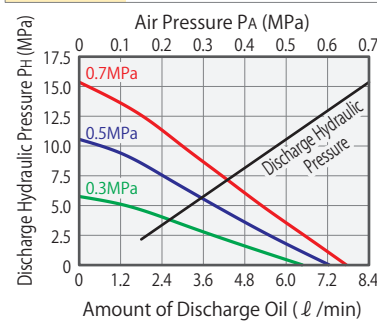

AC6001 Calculation Formula $P_H = 37(P_A - 0.06)$

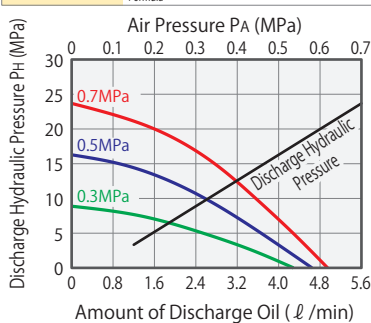

AC7001 Calculation Formula $P_H = 60(P_A - 0.06)$

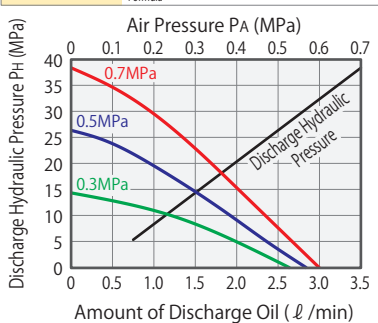

AC8001 Calculation Formula $P_H = 94(P_A - 0.06)$

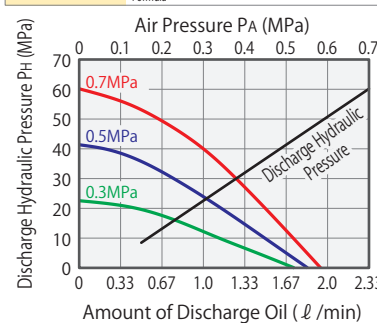

AC9001 Calculation Formula $P_H = 147(P_A - 0.06)$

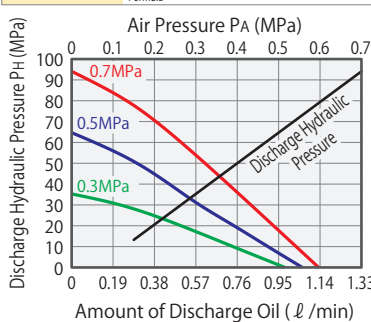

Pump Performance Curve

[How to calculate necessary air supply pressure for the set discharge pressure]
 • This can be determined by drawing a line from the discharge pressure P_H - - - - -
 (Ex.) Air pressure that is necessary for oil discharge pressure of 7MPa is about 0.51 MPa.

[How to calculate discharge pressure from the air pressure]
 • Discharge pressure P_H can be calculated by putting the air pressure P_A into the formula.
 (Ex.) Discharge pressure is about 7MPa when air pressure is 0.51MPa.

[How to calculate oil discharge volume]
 • Refer to the **Curve A** for the amount of discharge oil.
 (Ex.) At 0.5MPa air pressure:
 Discharge oil volume under no load is about 4.6 l/min.
 When the pump is operating under 3MPa load, the discharge oil volume is about 3.3 l/min.

AB4000 Calculation Formula $P_H = 15(P_A - 0.04)$

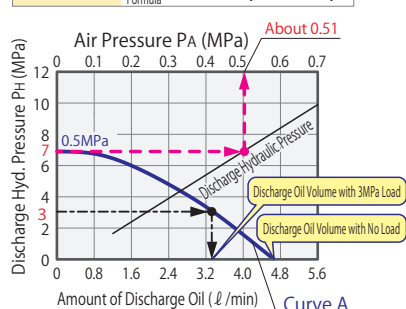

※ P_H : Discharge Pressure (MPa)
 P_A : Air Pressure (MPa)

External Dimensions

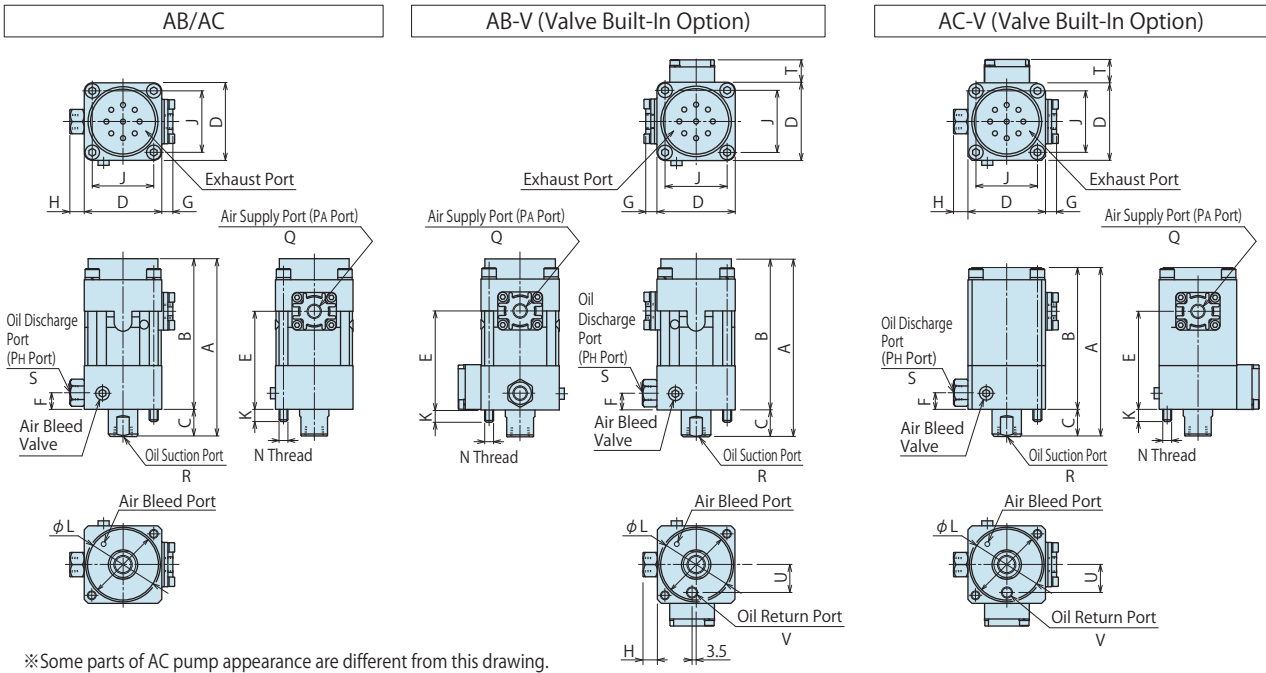

Machining Dimensions of
Mounting Hole (Common)

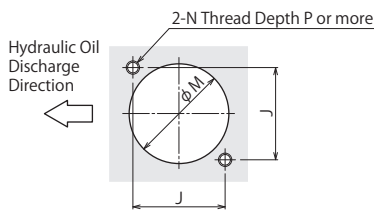

Model No.	AB□0	AC3001/4001	AC5001~9001
A	160	220.5	213.5
B	136		188.5
C	24	32	25
D	70		110
E	88.5		140
F	15		22
G	10		13
H	13		17
J	55.5		87
K	11		15
L	64		99.5
M	60		95
N	M8×1.25	M12×1.75	
P	13	18	
Q	Rc1/4	Rc1/2	
R	Rc3/8	Rc1/2	Rc3/8
S	Rc1/4	Rc3/8	Rc1/4
T	20	30	
U	25	40	
V	Rc1/8	Rc1/4	

Caution (AB/AC)

- When using an air circuit on the incoming side of the pump, please make sure to install the air filter and regulator. It can cause a malfunction due to dust in the piping.
- Always use a suction filter at the pump suction side. If you are not using Kosmek filter, we recommended using 100 or more mesh.
- Use a pipe having no rust or scale internally as a suction pipe. Remove burrs from thread part sufficiently. When installing apply a seal material such as seal tape to prevent air from entering.
- AB/AC pump is not suitable for continuous operation (circulation or open circuit). Always use in a closed circuit. Continuous operation results in packing wear, adversely affecting the pump life.
- When installing a purchased hydraulic valve in the hydraulic circuit, the pump may not balance to stop due to internal leakage of the valve. Continuous operation reduces the pump life. Use a non-leak valve and control valve made by Kosmek.
- The pump discharges oil in pulses. An accumulator can be installed to reduce pulsations.

Accessory (Suction Filter)

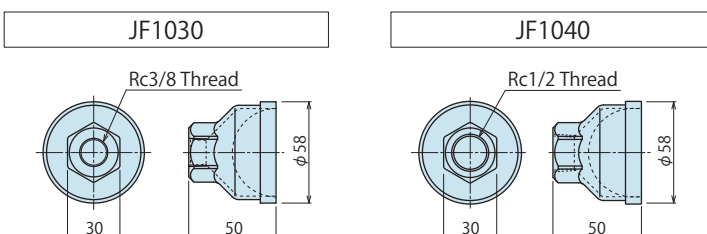

Model No. Indication

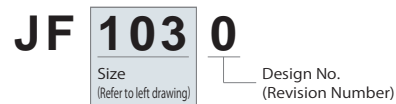

Model No.	JF1030	JF1040	
Applicable Pump Part Number	AB□0 AC5001 AC6001 AC7001	AC8001 AC9001	AC3001 AC4001

- High-Power Series
- Pneumatic Series
- Hydraulic Series
- Valve / Coupler Hydraulic Unit
- Manual Operation Accessories
- Cautions / Others
- Air Sequence Valve
 - BWD
- Hydraulic Non-Leak Coupler
 - BGA/BGB
 - BGC/BGD
 - BGP/BGS
 - BBP/BBS
 - BNP/BNS
 - BJP/BSJ
 - BFP/BFS

- Auto Coupler
 - JTA/JTB
 - JTC/JTD
 - JVA/JVB
 - JVC/JVD
 - JVE/JVF
 - JNA/JNB
 - JNC/JND
 - JLP/JLS

- Rotary Joint
 - JR

- Hydraulic Valve
 - BK
 - BEQ
 - BT
 - BLS/BLG
 - BLB
 - JSS/JS
 - JKA/JKB
 - BMA/BMG
 - AU/AU-M
 - BU
 - BP/JPB
 - BX
 - BEP/BSP
 - BH
 - BC

- Air Hydraulic Unit
 - CV
 - CK
 - CP/CPB
 - CPC/CQC
 - CB
 - CC
 - AB/AB-V
 - AC/AC-V

● Cautions

● Installation Notes (For Hydraulic Series)

- 1) Check the Usable Fluid
 - Please use the appropriate fluid by referring to the Hydraulic Fluid List.
- 2) Procedure before Piping
 - The pipeline, piping connector and fixture circuits should be cleaned by thorough flushing.
 - The dust and cutting chips in the circuit may lead to fluid leakage and malfunction.
 - There is no filter provided with Kosmek's product except for a part of valves which prevents foreign materials and contaminants from getting into the circuit.
- 3) Applying Sealing Tape
 - Wrap with tape 1 to 2 times following the screw direction.
 - Pieces of the sealing tape can lead to oil leakage and malfunction.
 - Please implement piping construction in a clear environment to prevent anything getting in products.
- 4) Air Bleeding of the Hydraulic Circuit
 - If the hydraulic circuit has excessive air, the action time may become very long. If air enters the circuit after connecting the hydraulic port or under the condition of no air in the oil tank, please perform the following steps.
 - ① Reduce hydraulic pressure to less than 2MPa.
 - ② Loosen the cap nut of pipe fitting closest to the clamp by one full turn.
 - ③ Shake the pipeline to loosen the outlet of pipe fitting.
Hydraulic fluid mixed with air comes out.

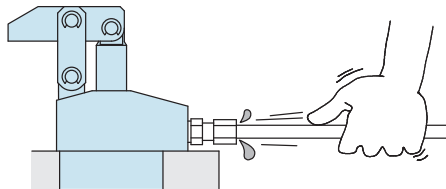

- ④ Tighten the cap nut after bleeding.
- ⑤ It is more effective to release air at the highest point inside the circuit or at the end of the circuit.
(Set an air bleeding valve at the highest point inside the circuit.)

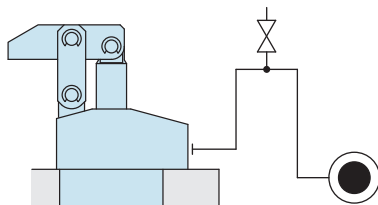

5) Checking Looseness and Retightening

- At the beginning of the machine installation, the bolt and nut may be tightened lightly. Check the looseness and re-tighten as required.

● Hydraulic Fluid List

Maker	ISO Viscosity Grade ISO-VG-32	
	Anti-Wear Hydraulic Oil	Multi-Purpose Hydraulic Oil
Showa Shell Sekiyu	Tellus S2 M 32	Morlina S2 B 32
Idemitsu Kosan	Daphne Hydraulic Fluid 32	Daphne Super Multi Oil 32
JX Nippon Oil & Energy	Super Hyrando 32	Super Mulpus DX 32
Cosmo Oil	Cosmo Hydro AW32	Cosmo New Mighty Super 32
ExxonMobil	Mobil DTE 24	Mobil DTE 24 Light
Matsumura Oil	Hydol AW-32	
Castrol	Hyspin AWS 32	

Note : Please contact manufacturers when customers require products in the list above.

● Notes on Hydraulic Cylinder Speed Control Unit



Please pay attention to the cautions below. Design the hydraulic circuit for controlling the action speed of hydraulic cylinder. Improper circuit design may lead to malfunctions and damages. Please review the circuit design in advance.

● Flow Control Circuit for Single Acting Cylinder

For spring return single acting cylinders, restricting flow during release can extremely slow down or disrupt release action. The preferred method is to control the flow during the lock action using a valve that has free-flow in the release direction. It is also preferred to provide a flow control valve at each actuator.

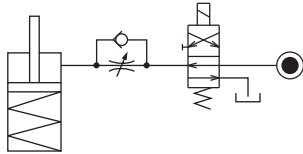

Accelerated clamping speed by excessive hydraulic flow to the cylinder may sustain damage. In this case add flow control to regulate flow. (Please add flow control to release flow if the lever weight is put on at the time of release action when using swing clamps.)

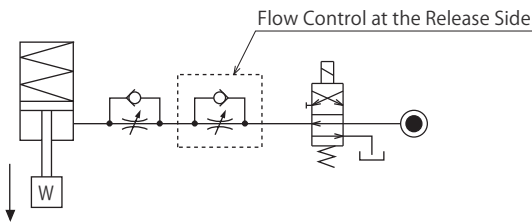

● Flow Control Circuit for Double Acting Cylinder

Flow control circuit for double acting cylinder should have meter-out circuits for both the lock and release sides. Meter-in control can have adverse effect by presence of air in the system.

However, in the case of controlling LKE, TMA, TLA, both lock side and release side should be meter-in circuit.

Refer to P.75 for speed adjustment of LKE.

For TMA and TLA, if meter-out circuit is used, abnormal high pressure is created, which causes oil leakage and damage.

【Meter-out Circuit】 (Except LKE/TMA/TLA)

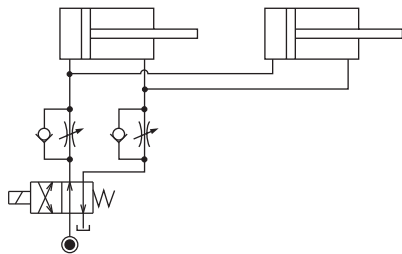

【Meter-in Circuit】 (LKE/TMA/TLA must be controlled with meter-in.)

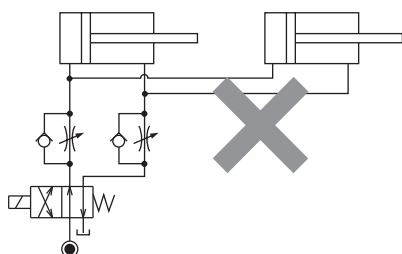

In the case of meter-out circuit, the hydraulic circuit should be designed with the following points.

- ① Single acting components should not be used in the same flow control circuit as the double acting components. The release action of the single acting cylinders may become erratic or very slow.

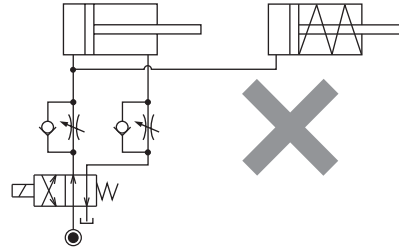

Refer to the following circuit when both the single acting cylinder and double acting cylinder are used together.

- Separate the control circuit.

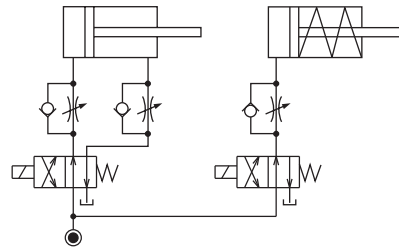

- Reduce the influence of double acting cylinder control unit. However, due to the back pressure in tank line, single action cylinder is activated after double action cylinder works.

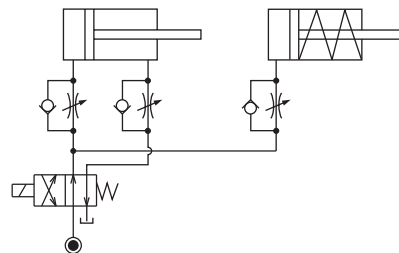

- ② In the case of meter-out circuit, the inner circuit pressure may increase during the cylinder action because of the fluid supply. The increase of the inner circuit pressure can be prevented by reducing the supplied fluid beforehand via the flow control valve. Especially when using sequence valve or pressure switches for clamping detection. If the back pressure is more than the set pressure then the system will not work as it is designed to.

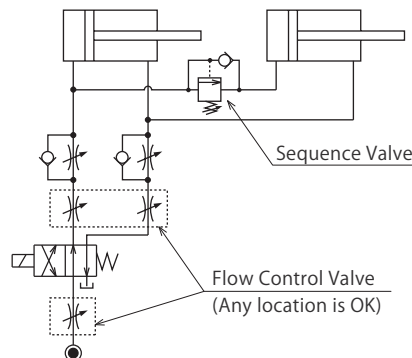

- High-Power Series
- Pneumatic Series
- Hydraulic Series
- Valve / Coupler Hydraulic Unit
- Manual Operation Accessories
- Cautions / Others

Cautions

- Installation Notes (For Hydraulic Series)
- Hydraulic Fluid List
- Notes on Hydraulic Cylinder Speed Control Circuit
- Notes on Handling
- Maintenance/Inspection
- Warranty

Company Profile

- Company Profile
- Our Products
- History

Index

- Search by
- Alphabetical Order

Sales Offices

ⓘ Cautions

● Notes on Handling

- 1) It should be operated by qualified personnel.
 - The hydraulic machine and air compressor should be operated and maintained by qualified personnel.
- 2) Do not operate or remove the product unless the safety protocols are ensured.
 - ① The machine and equipment can only be inspected or prepared when it is confirmed that the safety devices are in place.
 - ② Before the product is removed, make sure that the above-mentioned safety devices are in place. Shut off the pressure and power source, and make sure no pressure exists in the air and hydraulic circuits.
 - ③ After stopping the product, do not remove until the temperature drops.
 - ④ Make sure there is no abnormality in the bolts and respective parts before restarting the machine or equipment.
- 3) Do not touch a clamp (cylinder) while it is working. Otherwise, your hands may be injured due to clinching.



- 4) Do not disassemble or modify.
 - If the equipment is taken apart or modified, the warranty will be voided even within the warranty period.

● Maintenance and Inspection

- 1) Removal of the Machine and Shut-off of Pressure Source
 - Before the machine is removed, make sure that safety devices and preventive devices are in place. Shut off the pressure and power source, and make sure no pressure exists in the air and hydraulic circuits.
 - Make sure there is no abnormality in the bolts and respective parts before restarting.
- 2) Regularly clean the area around the piston rod and plunger.
 - If it is used when the surface is contaminated with dirt, it may lead to packing seal damage, malfunctioning and fluid leakage.

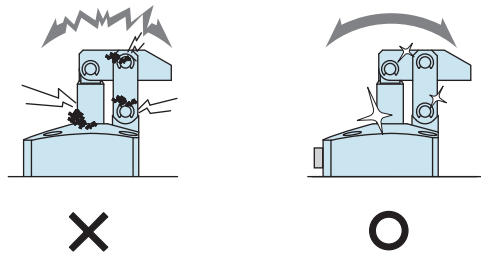

- 3) Please clean out the reference surfaces on a regular basis (taper reference surface and seating surface) of the locating products. (VS/VT/VFL/VFM/VFJ/VFK/WVS/VWM/VWK/VX/VXE/VXF)
 - The locating products, except VX/VXE/VXF model, can remove contaminants with cleaning functions. However, hardened cutting chips, adhesive coolant and others may not be removed. Make sure there are no contaminants before installing a workpiece/pallet.
 - Continuous use with contaminant on components will lead to locating accuracy failure, malfunction and fluid leakage.

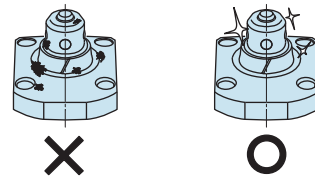

- 4) If disconnecting by couplers, air bleeding should be carried out on a regular basis to avoid air mixed in the circuit.
- 5) Regularly tighten nut, bolt, pin, cylinder, pipe line and others to ensure proper use.
- 6) Make sure the hydraulic fluid has not deteriorated.
- 7) Make sure there is a smooth action without an irregular noise.
 - Especially when it is restarted after left unused for a long period, make sure it can be operated correctly.
- 8) The products should be stored in the cool and dark place without direct sunshine or moisture.
- 9) Please contact us for overhaul and repair.

Cautions
[Installation Notes
\(For Hydraulic Series\)](#)
[Hydraulic Fluid List](#)
[Notes on Hydraulic Cylinder
Speed Control Circuit](#)
[Notes on Handling](#)
[Maintenance/
Inspection](#)
[Warranty](#)

Company Profile

[Company Profile](#)
[Our Products](#)
[History](#)

Index

[Search by
Alphabetical Order](#)

Sales Offices

● Warranty

1) Warranty Period

- The product warranty period is 18 months from shipment from our factory or 12 months from initial use, whichever is earlier.

2) Warranty Scope

- If the product is damaged or malfunctions during the warranty period due to faulty design, materials or workmanship, we will replace or repair the defective part at our expense.

Defects or failures caused by the following are not covered.

- ① If the stipulated maintenance and inspection are not carried out.
- ② If the product is used while it is not suitable for use based on the operator's judgment, resulting in defect.
- ③ If it is used or operated in an inappropriate way by the operator. (Including damage caused by the misconduct of the third party.)
- ④ If the defect is caused by reasons other than our responsibility.
- ⑤ If repair or modifications are carried out by anyone other than Kosmek, or without our approval and confirmation, it will void warranty.
- ⑥ Other caused by natural disasters or calamities not attributable to our company.
- ⑦ Parts or replacement expenses due to parts consumption and deterioration. (Such as rubber, plastic, seal material and some electric components.)

Damages excluding from direct result of a product defect shall be excluded from the warranty.

Sales Offices

Sales Offices across the World

Japan	KOSMEK LTD. HEAD OFFICE	TEL. +81-78-991-5162 FAX. +81-78-991-8787 1-5, 2-chome, Murotani, Nishi-ku, Kobe-city, Hyogo, Japan 651-2241
USA	KOSMEK (USA) LTD. Overseas Subsidiary	TEL. +1-630-620-7650 FAX. +1-630-620-9015 650 Springer Drive, Lombard, IL 60148 USA
	KOSMEK USA ATLANTA BRANCH OFFICE	TEL. +1-630-620-7650 303 Perimeter Center North, Suite 300, Atlanta, GA 30346 USA
Mexico	KOSMEK USA MEXICO BRANCH OFFICE	TEL. +52-442-851-1377 Av. Loma Pinal de Amoles 320-piso PH oficina 504 interior 13, Vista Dorada, 76060 Santiago de Querétaro, Qro. Mexico
Europe	KOSMEK EUROPE GmbH Overseas Subsidiary	TEL. +43-463-287587 FAX. +43-463-287587-20 Schleppeplatz 2 9020 Klagenfurt am Wörthersee Austria
China	KOSMEK (CHINA) LTD. Overseas Subsidiary	TEL.+86-21-54253000 FAX. +86-21-54253709 Room601, RIVERSIDE PYRAMID No.55, Lane21, Pusan Rd, Pudong Shanghai China
	KOSMEK (CHINA) LTD. Dongguan Office Overseas Subsidiary (Sales Office)	TEL.+86-769-85300880 Room 603, Xinchuang Power Building (No. 122-1 West Houjie Avenue), Houjie Town, Dongguan City, Guangdong Province, China
	KOSMEK (CHINA) LTD. Wuhan Office Overseas Subsidiary (Sales Office)	TEL.+86-15802172393 Room 309, Chuangu Technology Building, 266 Taizihu Rd, Zhuankou Subdistrict, Caidian District, Wuhan 430056, Hubei Province, China
India	KOSMEK LTD. - INDIA Branch	TEL. +91-9880561695 4A/Old No:649, Ground Floor, 4th D cross, MM Layout, Kavalbyrasandra, RT Nagar, Bangalore -560032 India
Thailand	KOSMEK Thailand Representative Office Representative Office	TEL. +66-2-300-5132 FAX. +66-2-300-5133 67 Soi 58, RAMA 9 Rd., Phatthanakan, Suanluang, Bangkok 10250, Thailand
Taiwan	FULL LIFE TRADING CO., LTD. Distributor	TEL. +886-2-82261860 FAX. +886-2-82261890 16F-4, No.2, Jian Ba Rd., Zhonghe District, New Taipei City Taiwan 23511
Philippines	G.E.T. Inc, Phil. Distributor	TEL.+63-2-310-7286 FAX. +63-2-310-7286 Victoria Wave Special Economic Zone Mt. Apo Building, Brgy. 186, North Caloocan City, Metro Manila, Philippines 1427
Indonesia	PT. Yamata Machinery Sales Distributor	TEL. +62-21-29628607 FAX. +62-21-29628608 Delta Commercial Park I, Jl. Kenari Raya B-08, Desa Jayamukti Kec. Cikarang Pusat Kab. Bekasi 17530 Indonesia

Sales Offices in Japan

Head Office Osaka Sales Office Overseas Sales	TEL. 078-991-5162 FAX. 078-991-8787 1-5, 2-chome, Murotani, Nishi-ku, Kobe-city, Hyogo, 651-2241, Japan
Tokyo Sales Office	TEL. 048-652-8839 FAX. 048-652-8828 81, 4-chome, Onari-cho, Kita-ku, Saitama City, Saitama, 331-0815, Japan
Nagoya Sales Office	TEL. 0566-74-8778 FAX. 0566-74-8808 10-1, 2-chome, Misono-cho, Anjo City, Aichi, 446-0076, Japan
Fukuoka Sales Office	TEL. 092-433-0424 FAX. 092-433-0426 8-10-101, 1-chome, Kamimuta, Hakata-ku, Fukuoka City, Fukuoka, 812-0006, Japan

Global Network

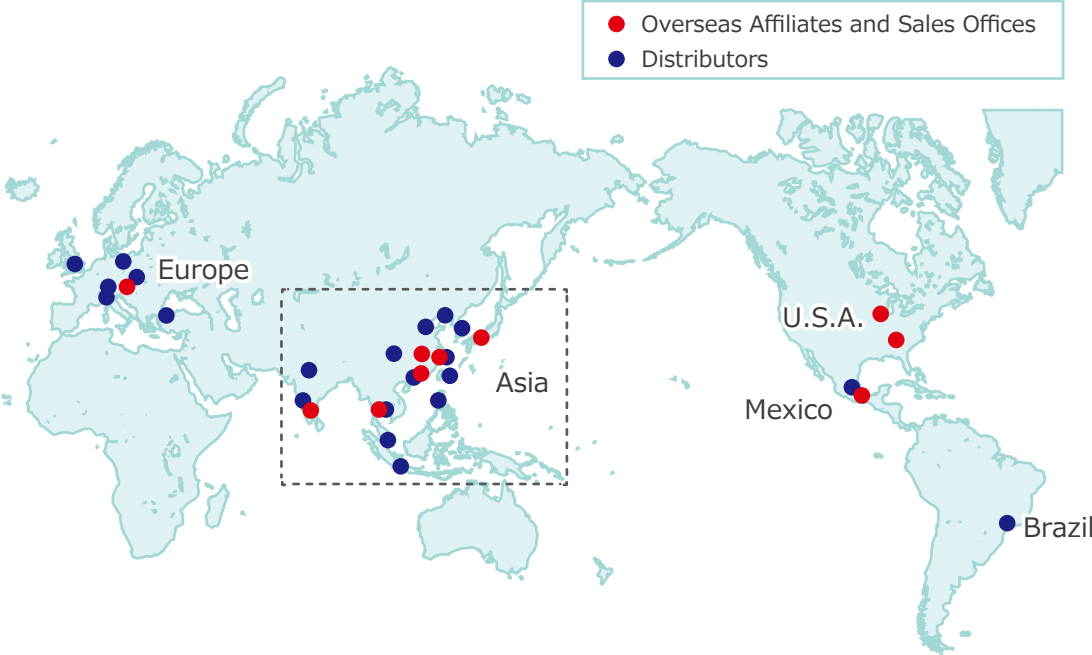

Asia Detailed Map



● FOR FURTHER INFORMATION ON UNLISTED SPECIFICATIONS AND SIZES, PLEASE CALL US.
 ● SPECIFICATIONS IN THIS CATALOG ARE SUBJECT TO CHANGE WITHOUT NOTICE.

