

New

Medium-Pressure Link Clamp



Model TQA

Hydraulic Link Clamp

Operating Pressure : 2~21MPa

Medium-Pressure Link Clamp

Hydraulic Double Action

Model TQA



Additional Line-up : TQA0300/0450

Compact Medium-Pressure Clamp

Lightweight and space-saving fixture design. Unclamp Confirmation Option Selectable.

Compact Medium-Pressure Clamp

Body Size : Min. ϕ 20mm

Operating Pressure : 2 ~ 21MPa

※In case of Standard Model

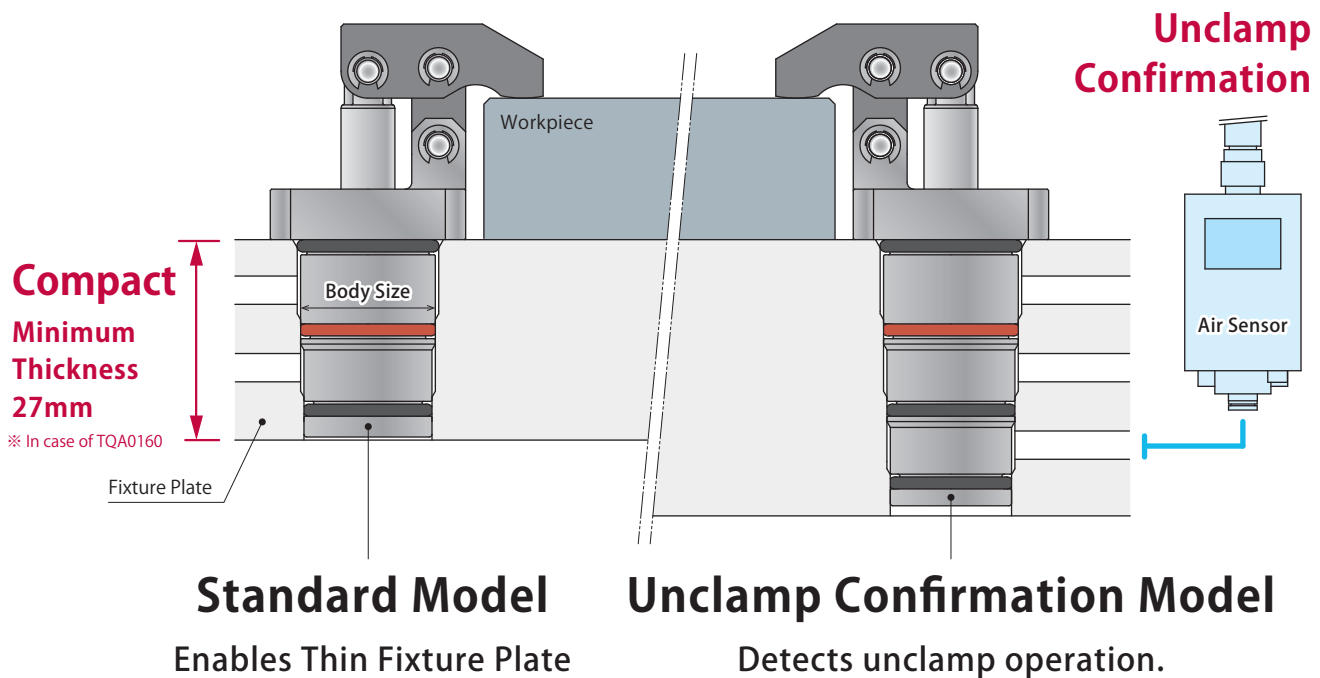

Model No.	TQA0160	TQA0300	TQA0450
Body Size mm	ϕ 20	ϕ 24	ϕ 29
Clamping Force (with Standard Lever) kN	1.5	2.9	4.2

● Features

● Thin Fixture Plate

The dimension below flange is short to enable thinner and lighter fixtures.

The flange is also compact, allowing for installation in limited spaces.

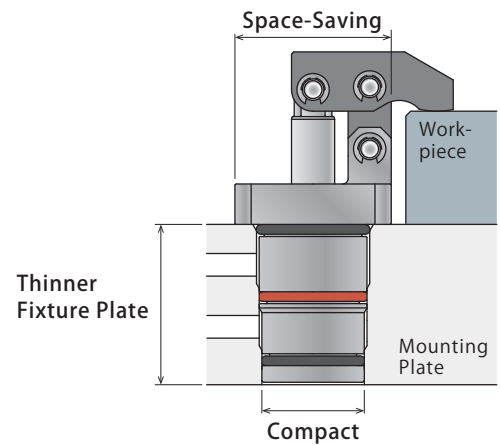

● Protective Wall Prevents Damage to Dust Seal

The protective wall prevents damage to the internal dust seal and maintains high sealing over an extended period.

The dust seal also has high durability against chlorine-based coolant by using a sealing material with excellent chemical resistance.

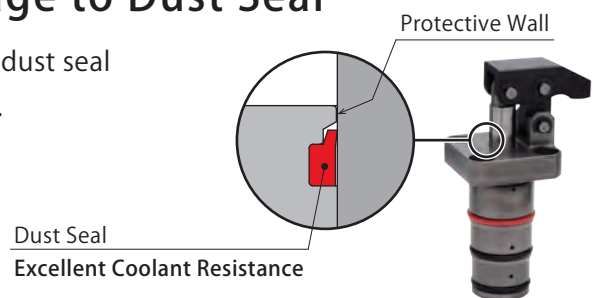

● Unclamp Confirmation

An air sensor enables unclamp confirmation.

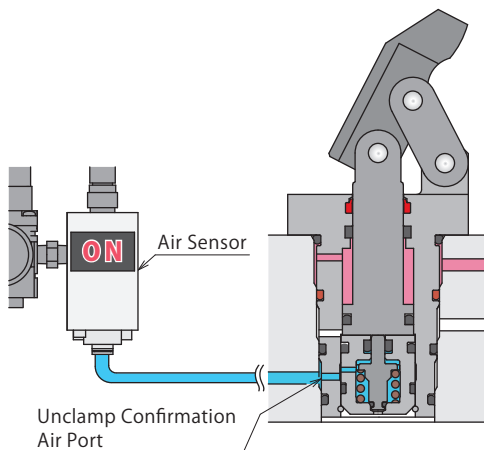

● Easy Machining of Cartridge Cavity

Cartridge cavity does not require any special tooling for recess machining. The maximum corresponding port hole diameter is large, allowing for easy machining.

Machining Possible
with Standard Tools

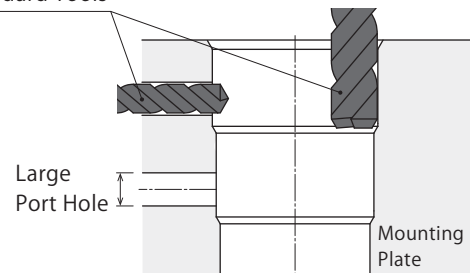

● Different sizes can be arranged without changing port height

Design and machining are simple even for fixtures with different cylinder sizes mounted together at the same port height. ※ Only for the standard model (no action confirmation).

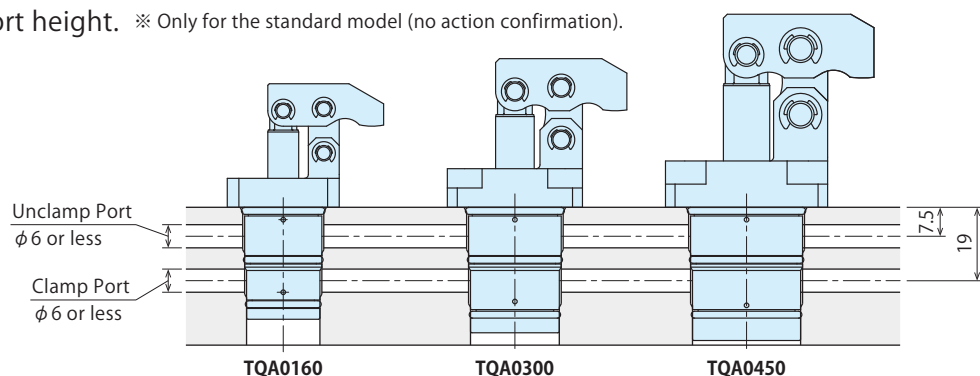

● Action Description

Standard Model (No Action Confirmation)

In case of **3** Action Confirmation Symbol : **Blank**
 ※ Refer to the 'model no. indication' on P.7 for the action confirmation symbol.

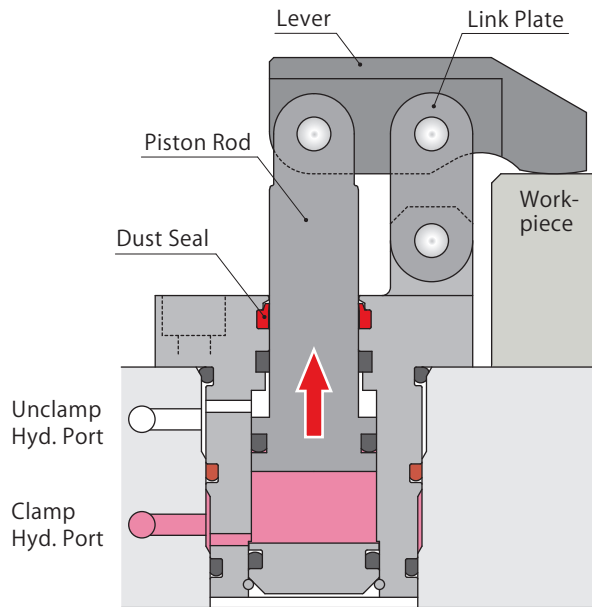

■ Clamping Action

The piston rod ascends and clamps the workpiece.

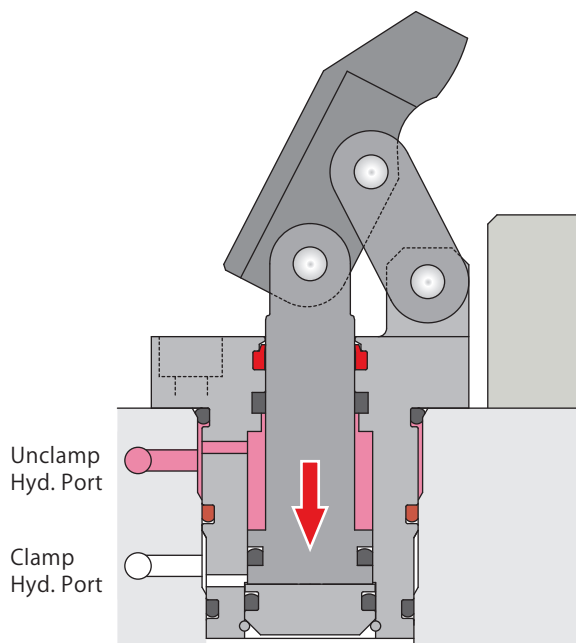

■ Unclamping Action

The piston rod descends.

Unclamp Confirmation Model

Unclamp operation can be confirmed using an air sensor.

In case of **3** Action Confirmation Symbol : **Unclamp Confirmation**

※ Refer to the 'model no. indication' on P.7 for the action confirmation symbol.

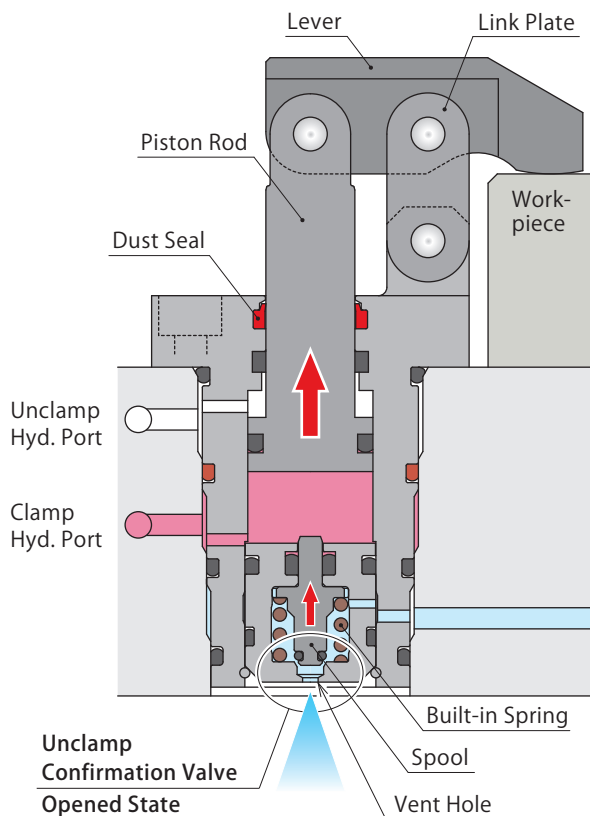

■ Clamping Action

The piston rod ascends and clamps the workpiece. The spool is pushed upward by the built-in spring and the unclamp confirmation valve is opened.

Hydraulic Pressure		Air Sensor
Clamp Side	Unclamp Side	Unclamp Check Output
ON	OFF	OFF

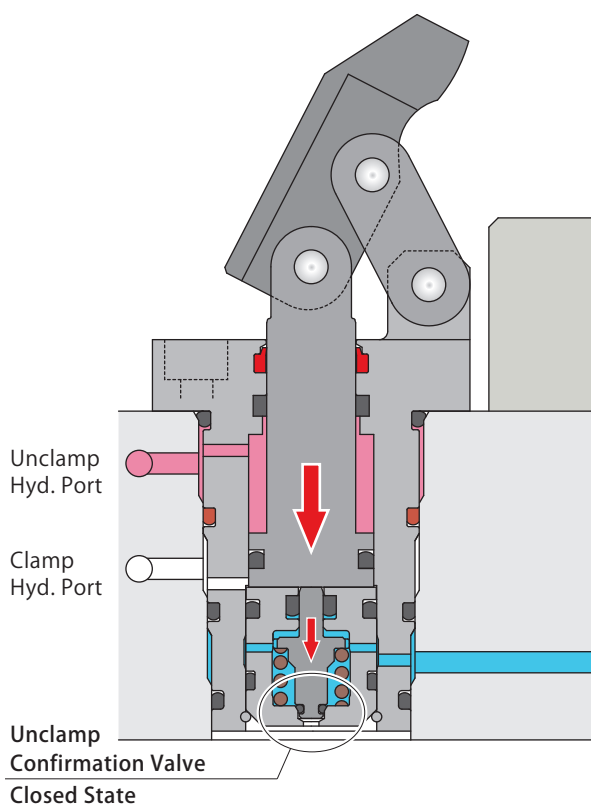
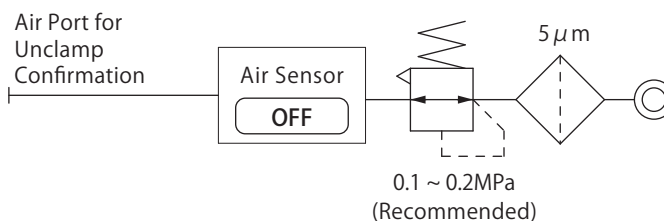

■ Unclamping Action

The piston rod descends. The spool is pushed downward compressing the built-in spring and the unclamp confirmation valve is closed.

Hydraulic Pressure		Air Sensor
Clamp Side	Unclamp Side	Unclamp Check Output
OFF	ON	ON

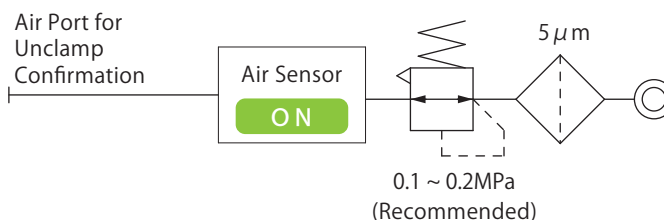

● Action Description (Action Confirmation and Air Sensing Chart)

Action confirmation can be conducted by detecting differential pressure with an air sensor.

Applicable Model

TQA 016 0 - J - Blank A

3 Action Confirmation Symbol
J : Unclamp Confirmation

Air Sensor

- Air catch sensor is required in order to conduct the action confirmation.

Sensing can be done by the air catch sensor with small air flow (recommended models are in the chart below).

Recommended Operating Air Pressure : 0.1~0.2MPa

Recommended Air Sensor

Manufacturer	SMC	CKD
Name	Air Catch Sensor	Gap Switch
Model No.	ISA3-G	GPS3-E

- Please refer to manufacturer's catalog or other documents for the details about the air catch sensor.
- The air pressure to the air catch sensor should be 0.1~ 0.2MPa.
- Please keep supplying air pressure when in use.
- Refer to the drawing below for the air circuit structure.



Notes for Design • Installation • Use

- Please keep clear condition at the air vent port / vent hole, and prevent coolant and chips from entering the port / hole. The air sensor can malfunction if the air vent port is blocked.
- Prevention of Contaminants to the Air Vent Port / Vent Hole
Coolant and chips can be prevented by setting a check valve with low cracking pressure. (Recommended check valve: SMC-made series AKH, cracking pressure: 0.005MPa)

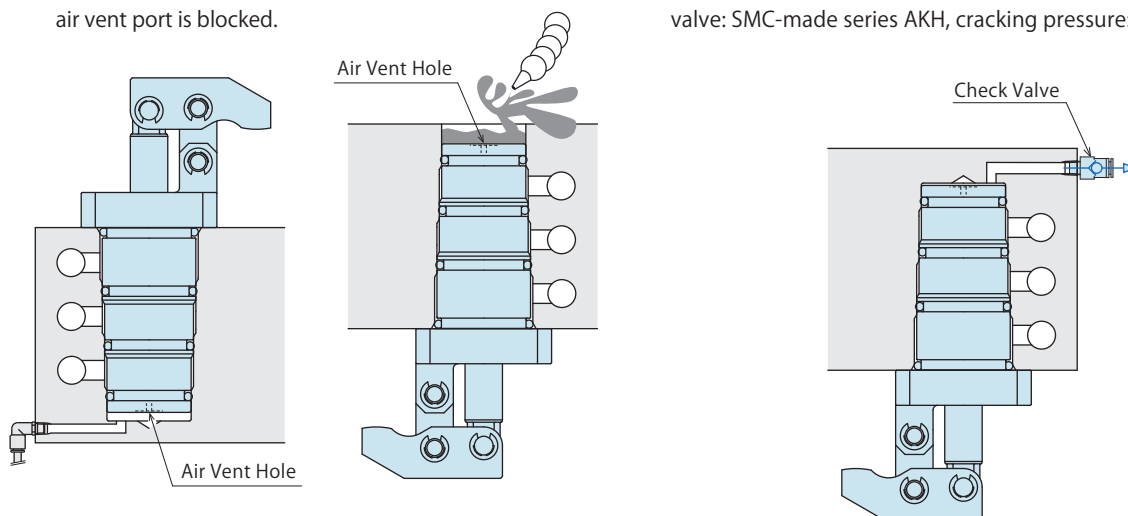

- Keep clear condition at the air vent port / hole.
- ✗ Coolant and chips enter from the air vent hole.

- Keep supplying air pressure to the air port when in use.

Air Sensing Chart

When Connected to 1 Clamp, Supply 0.2MPa Air Pressure

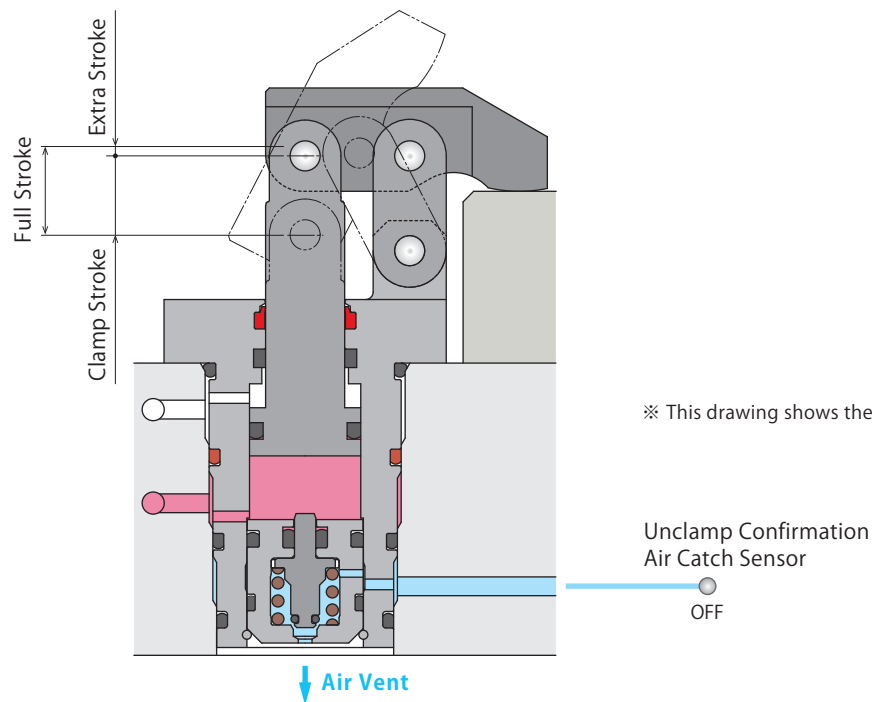
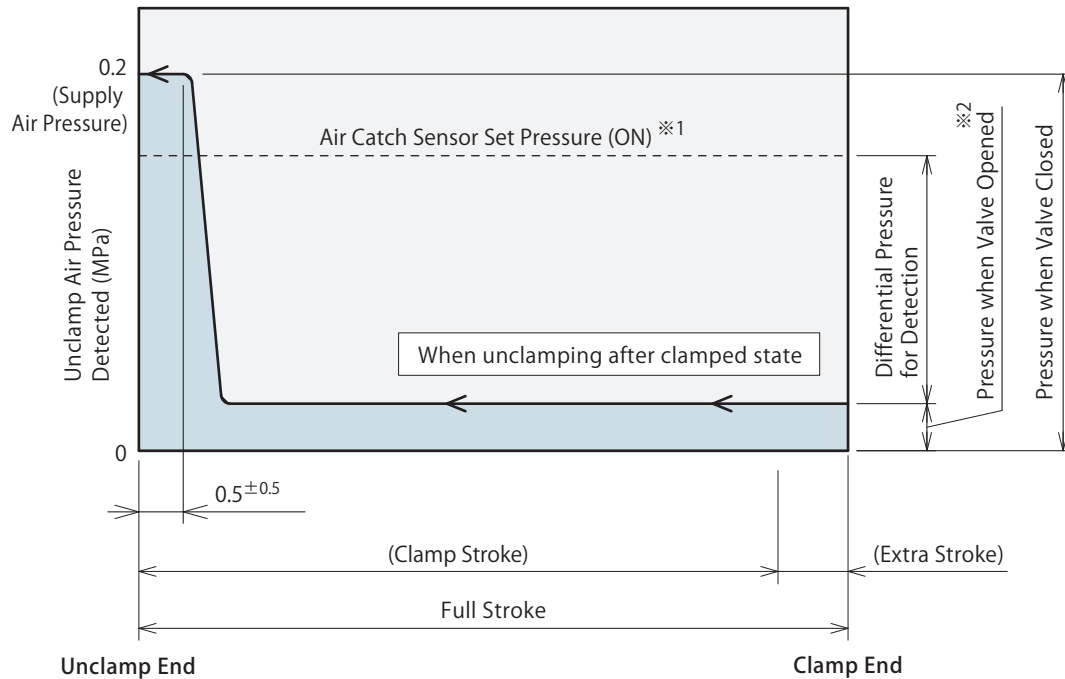

Notes :

1. The sensing chart shows the relationship between the stroke and detection circuit air pressure
2. The specifications may vary depending on the air circuit. The length of hose should be as short as possible. (Suggest shorter than 5m)
- ※1. The location of ON signal from air sensor output varies depending on the sensor setting.
- ※2. The sensor pressure for opening the valve depends on the sensor.

With air sensor with large air flow, the sensor pressure for opening the valve is higher and the differential pressure for detection is lower.

Model No. Indication

TQA 016 0 - J - A

1 2 3 4

1 Body Size

016 : $\phi D=20\text{mm}$

030 : $\phi D=24\text{mm}$

045 : $\phi D=29\text{mm}$

※ Outer diameter (ϕD) of the cylinder.

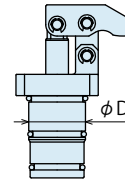

2 Design No.

0 : Revision Number

3 Action Confirmation Symbol

Blank : Standard (no action confirmation)

J : Unclamp Confirmation

4 Lever Option

Blank : Lever not included

A : Standard Lever included

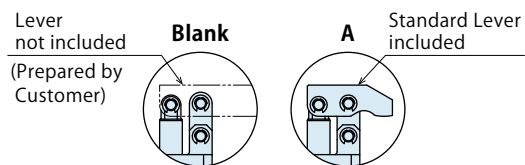

Specifications

Model No.		TQA0160-□-□	TQA0300-□-□	TQA0450-□-□		
Cylinder Area for Clamping	cm ²	0.950	1.767	2.545		
Cylinder Inner Diameter ^{※1}	mm	11	15	18		
Rod Diameter ^{※1}	mm	8	10	12		
Clamping Force ^{※1 ※2} (Calculation Formula)	kN	$F = \frac{0.90 \times P}{L - 10.5}$	$F = \frac{1.91 \times P}{L - 12}$	$F = \frac{3.21 \times P}{L - 14}$		
Full Stroke	mm	13.0	14.5	15.5		
Clamp Stroke	mm	11.5	13	14		
Extra Stroke	mm	1.5	1.5	1.5		
Cylinder Capacity	Clamp	cm ³	1.2	2.6	3.9	
	Unclamp	cm ³	0.6	1.4	2.2	
Hydraulic Pressure	Max. Operating Pressure	MPa	21.0			
	Min. Operating Pressure ^{※3}	In case of 3 Blank	MPa	2.0		
		In case of 3 J	MPa	5.0		
Withstanding Pressure	MPa	31.5				
Recommended Operating Air Pressure	In case of 3 J	MPa	0.1 ~ 0.2			
Recommended Air Sensor	In case of 3 J		ISA3-G : SMC-made / GPS3-E:CKD-made			
Operating Temperature	°C	0 ~ 70				
Usable Fluid		General Hydraulic Oil Equivalent to ISO-VG-32				
Weight	In case of 3 Blank	In case of 4 Blank	kg	0.11	0.20	0.35
		In case of 4 A	kg	0.13	0.23	0.40
	In case of 3 J	In case of 4 Blank	kg	0.13	0.22	0.39
		In case of 4 A	kg	0.15	0.25	0.44

Notes : ^{※1}. Clamping force cannot be calculated from the cylinder inner diameter and rod diameter.

Please refer to the clamping force calculation formula and the clamping force curve on P.9.

^{※2}. F : Clamping Force (kN), P : Supply Hydraulic Pressure (MPa),

L : Distance between the piston center and the clamping point (mm).

^{※3}. Minimum pressure to operate the clamp without load.

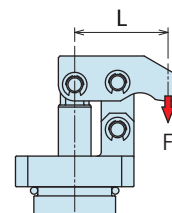

Clamping Force Curve

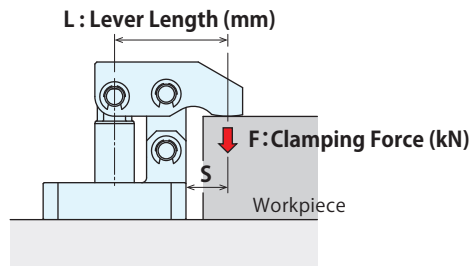

(How to Read the Clamping Force Curve)

In case of **TQA0160**: When supply hydraulic pressure P is 21MPa and lever length L is 23mm, clamping force becomes about 1.51kN.

Notes :

- ※1. F : Clamping Force (kN), P : Supply Hydraulic Pressure (MPa), L : Lever Length (mm)
Cylinder output (when L=0) cannot be calculated from the calculation formula of clamping force.
- 1. The table and the graph show the relationship between the clamping force (kN) and supply hydraulic pressure (MPa).
- 2. Values in the chart indicate clamping force when the lever locks a workpiece in horizontal position.
- 3. The clamping force varies depending on the lever length. Set the suitable supply hydraulic pressure based on the lever length.

TQA0160		Clamping Force Calculation Formula ※1 (kN)		$F = \frac{0.90 \times P}{L - 10.5}$							
Hydraulic Pressure (MPa)	Cylinder Force (kN)	Clamping Force (kN)									Min. Lever Length (L) (mm)
		Lever Length L (mm)									
		15	17	19.5	23 Std. Lever	26	30	35	40		
21	2.00				1.51	1.22	0.97	0.77	0.64	23	
18	1.71			1.80	1.30	1.05	0.83	0.66	0.55	19.5	
15	1.43		2.08	1.50	1.08	0.87	0.69	0.55	0.46	17	
14	1.33		1.94	1.40	1.01	0.81	0.65	0.51	0.43	16.5	
12	1.14		1.66	1.20	0.86	0.70	0.55	0.44	0.37	15.5	
10	0.95	2.00	1.38	1.00	0.72	0.58	0.46	0.37	0.31	15	
9	0.86	1.80	1.25	0.90	0.65	0.52	0.42	0.33	0.27	15	
7	0.67	1.40	0.97	0.70	0.50	0.41	0.32	0.26	0.21	15	
6	0.57	1.20	0.83	0.60	0.43	0.35	0.28	0.22	0.18	15	
5	0.48	1.00	0.69	0.50	0.36	0.29	0.23	0.18	0.15	15	
2	0.19	0.40	0.28	0.20	0.14	0.12	0.09	0.07	0.06	15	
Max. Operating Pressure (MPa)		11.9	15	18	21	21	21	21	21	21	

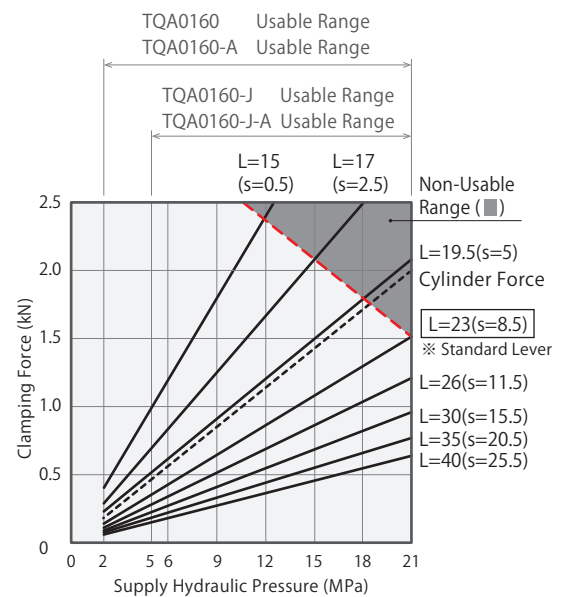

TQA0300		Clamping Force Calculation Formula ※1 (kN)		$F = \frac{1.91 \times P}{L - 12}$							
Hydraulic Pressure (MPa)	Cylinder Force (kN)	Clamping Force (kN)									Min. Lever Length (L) (mm)
		Lever Length L (mm)									
		20	22.5	26 Std. Lever	30	35	40	45			
21	3.71			2.87	2.23	1.74	1.43	1.22	26		
18	3.18		3.27	2.46	1.91	1.49	1.23	1.04	22.5		
15	2.65	3.58	2.73	2.05	1.59	1.25	1.02	0.87	20		
14	2.47	3.34	2.55	1.91	1.49	1.16	0.96	0.81	20		
12	2.12	2.87	2.18	1.64	1.27	1.00	0.82	0.69	20		
10	1.77	2.39	1.82	1.36	1.06	0.83	0.68	0.58	20		
9	1.59	2.15	1.64	1.23	0.96	0.75	0.61	0.52	20		
7	1.24	1.67	1.27	0.96	0.74	0.58	0.48	0.41	20		
6	1.06	1.43	1.09	0.82	0.64	0.50	0.41	0.35	20		
5	0.88	1.19	0.91	0.68	0.53	0.42	0.34	0.29	20		
2	0.35	0.48	0.36	0.27	0.21	0.17	0.14	0.12	20		
Max. Operating Pressure (MPa)		15.8	18.3	21	21	21	21	21	21		

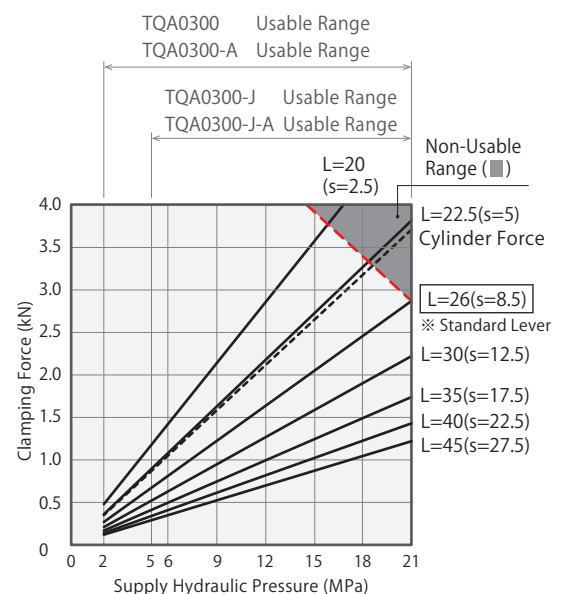

TQA0450		Clamping Force Calculation Formula ^{※1} (kN)							$F = \frac{3.21 \times P}{L - 14}$	
Hydraulic Pressure (MPa)	Cylinder Force (kN)	Clamping Force (kN)								Min. Lever Length (L) (mm)
		Lever Length L (mm)								
		23.5	26	30 Std. Lever	35	40	45	50		
21	5.34			4.21	3.21	2.59	2.17	1.87	30	
18	4.58		4.82	3.61	2.75	2.22	1.86	1.61	26	
15	3.82	5.07	4.01	3.01	2.29	1.85	1.55	1.34	23.5	
14	3.56	4.73	3.75	2.81	2.14	1.73	1.45	1.25	23.5	
12	3.05	4.05	3.21	2.41	1.83	1.48	1.24	1.07	23.5	
10	2.55	3.38	2.68	2.01	1.53	1.23	1.04	0.89	23.5	
9	2.29	3.04	2.41	1.81	1.38	1.11	0.93	0.80	23.5	
7	1.78	2.37	1.87	1.40	1.07	0.86	0.72	0.62	23.5	
6	1.53	2.03	1.61	1.20	0.92	0.74	0.62	0.54	23.5	
5	1.27	1.69	1.34	1.00	0.76	0.62	0.52	0.45	23.5	
2	0.51	0.68	0.54	0.40	0.31	0.25	0.21	0.18	23.5	
Max. Operating Pressure (MPa)		16.1	18.3	21	21	21	21	21		

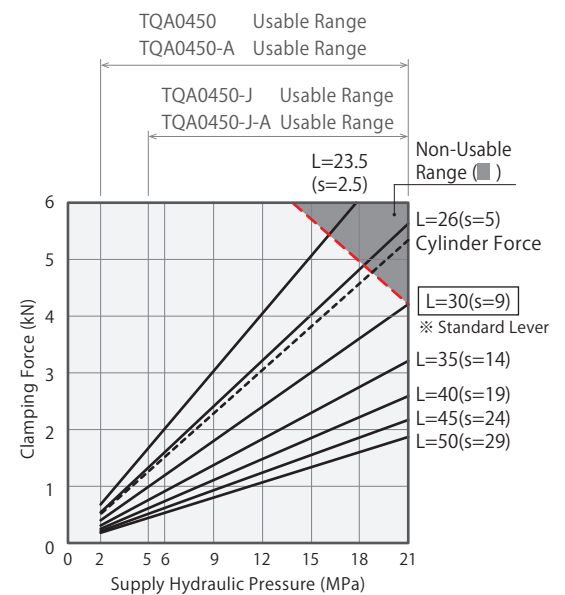

External Dimensions

TQA : Standard (No Action Confirmation)

※ The drawing shows the clamped state of TQA0160-A.

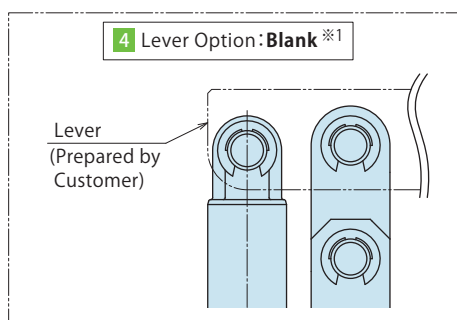
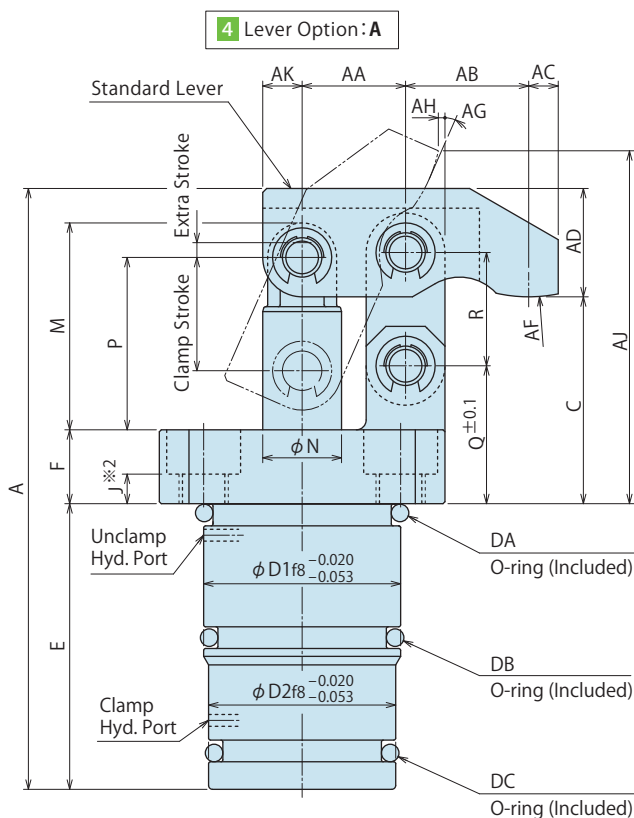
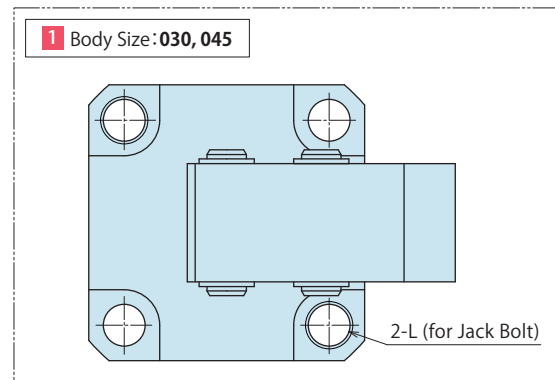
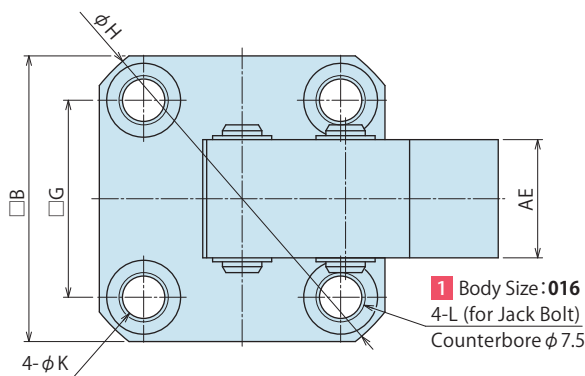

Notes :

- ※1. Please refer to 4 Lever Option : A for unlisted dimensions.
- ※2. Mounting bolts are not included. Please prepare them by customer.
- 1. Please use the provided pin as the lever mounting pin.

Machining Dimensions of Mounting Area

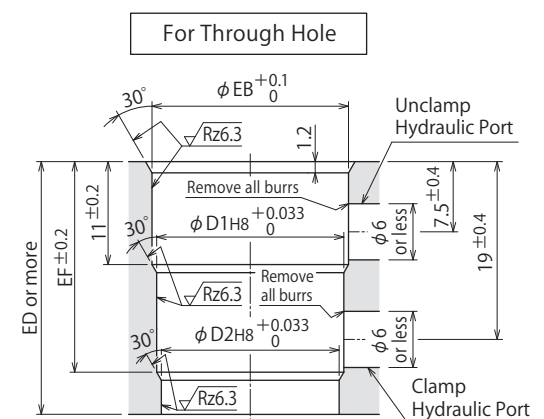
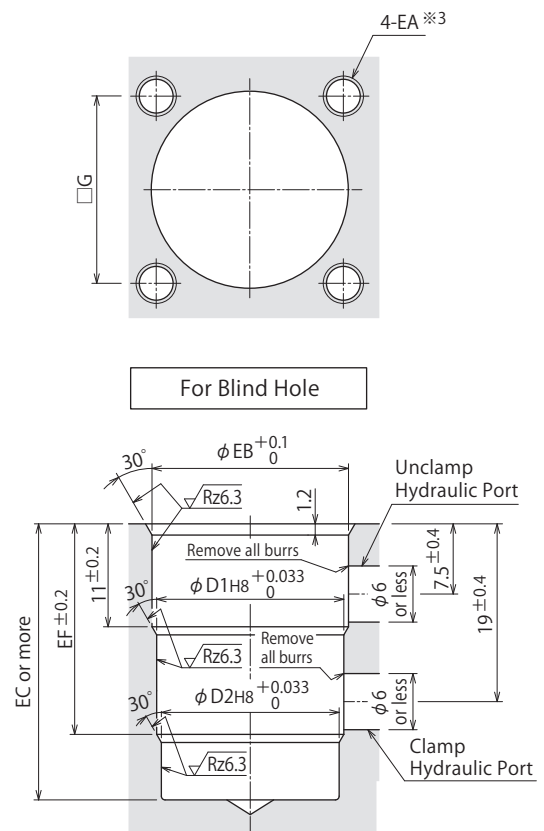

Note :

- ※3. Tapping depth of the mounting bolt should be decided according to the length of the bolt.

Model No. Indication

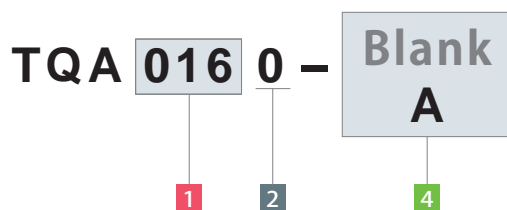

(Format Example : TQA0160-A,TQA0300)

1 Body Size

2 Design No.

4 Lever Option

External Dimensions and Machining Dimensions for Mounting (mm)

Model No.	TQA0160-□	TQA0300-□	TQA0450-□
Full Stroke	13	14.5	15.5
(Break down)	Clamp Stroke	11.5	13
	Extra Stroke	1.5	1.5
A	61	71	84.5
B	29	35	42
C	21	25	33.5
D1	20	24	29
D2	19	23	28
E	29	32.5	34.5
F	7.5	10	12
G	20	26	32
H	37	46	56
J	3	5	6
K	4.4	5.3	6.8
L (Nominal × Pitch)	M5×0.8	M6×1	M8×1.25
M	21	24.5	33
N	8	10	12
P	17.5	20	27.5
Q	14	17.5	24
R	11.5	13.5	17
AA	10.5	12	14
AB	12.5	14	16
AC	3	3	3
AD	11	13.5	16.5
AE	12	15	19
AF	R15	R20	R25
AG	23.7°	24.1°	28°
AH	0.7	1.3	0.4
AJ	35.8	41.5	51.9
AK	4	5	6
EA (Nominal × Pitch)	M4×0.7	M5×0.8	M6×1
EB	21	25	30
EC	29.5	33	35
ED	27	30	30
EF	22.5	25	25
DA	AS568-017(90)	AS568-020(90)	AS568-023(90)
DB	Inner Diam. 17.2× Wire Diam. 1.78	Inner Diam. 20.4× Wire Diam. 1.78	Inner Diam. 25.1× Wire Diam. 1.78
DC	AS568-016(90)	AS568-018(90)	AS568-022(90)

External Dimensions

TQA-J : Unclamp Confirmation

※ The drawing shows the clamped state of TQA0160-J-A.

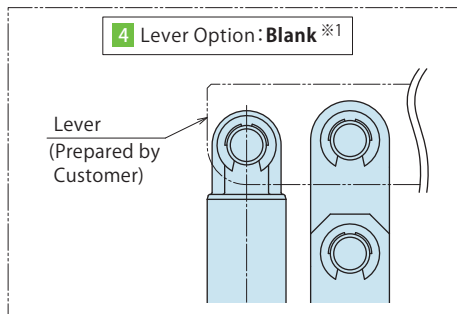
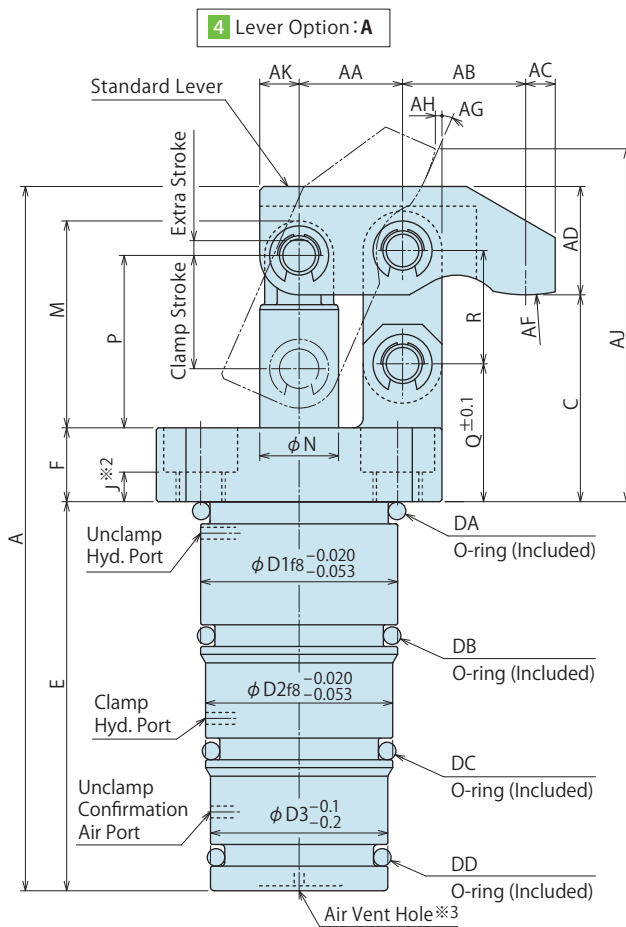
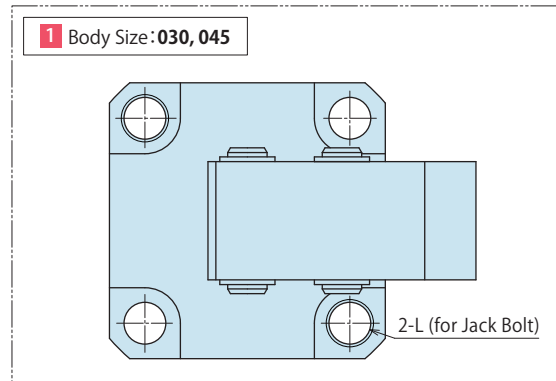
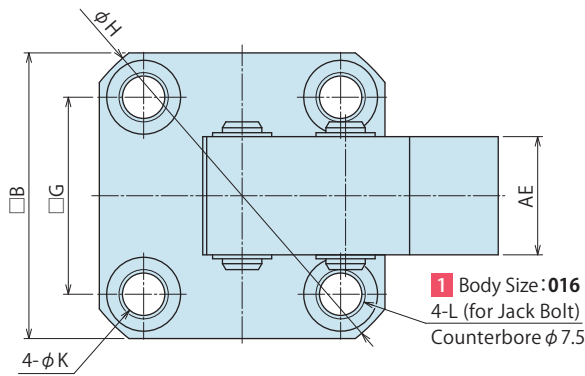

Notes:

- ※1. Please refer to 4 Lever Option : A for unlisted dimensions.
- ※2. Mounting bolts are not included. Please prepare them by customer.
- ※3. Please keep clear condition at the air vent hole, and prevent coolant and chips from entering the hole.
- 1. Please use the provided pin as the lever mounting pin.

Machining Dimensions of Mounting Area

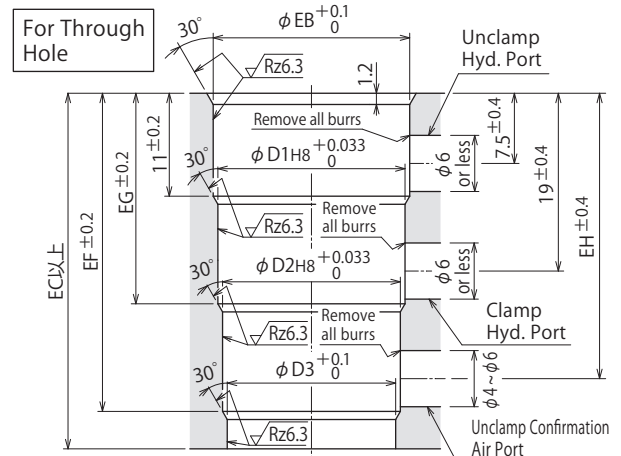
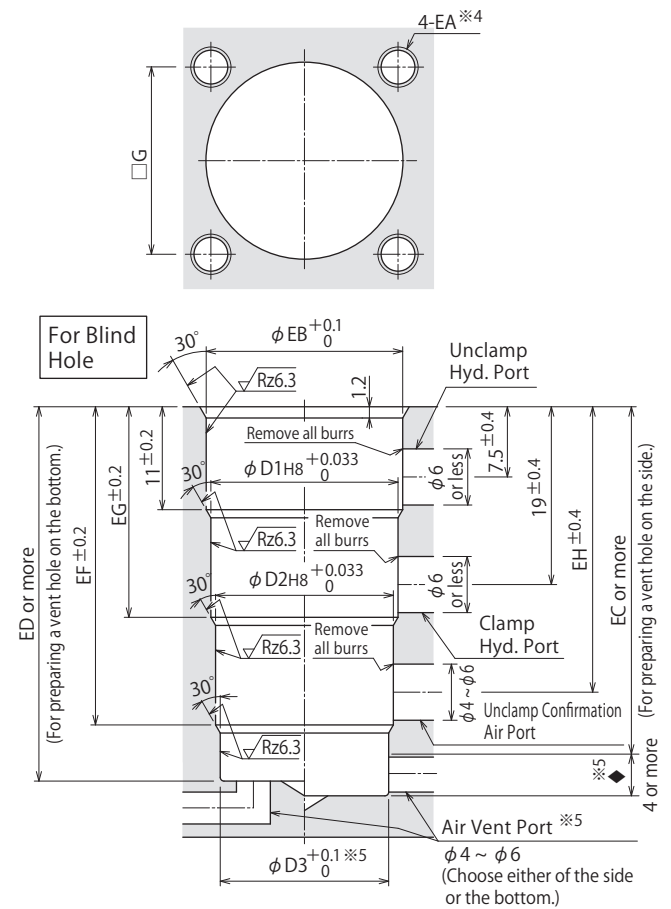

Note:

- ※4. Tapping depth of the mounting bolt should be decided according to the length of the bolt.
- ※5. Prepare the vent hole on the side or the bottom. When preparing on the side, it should be within the ♦ area. When preparing on the bottom, it should be within φD3.

Model No. Indication

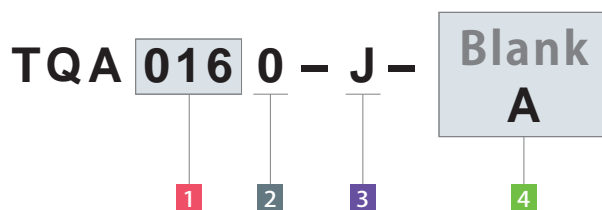

(Format Example : TQA0160-J-A,TQA0300-J)

- 1 Body Size
- 2 Design No.
- 3 Action Confirmation Symbol
- 4 Lever Option

External Dimensions and Machining Dimensions for Mounting (mm)

Model No.	TQA0160-J-□	TQA0300-J-□	TQA0450-J-□
Full Stroke	13	14.5	15.5
(Break down)	Clamp Stroke	11.5	13
	Extra Stroke	1.5	1.5
A	71.5	80.5	94
B	29	35	42
C	21	25	33.5
D1	20	24	29
D2	19	23	28
D3	18	22	27
E	39.5	42	44
F	7.5	10	12
G	20	26	32
H	37	46	56
J	3	5	6
K	4.4	5.3	6.8
L (Nominal × Pitch)	M5×0.8	M6×1	M8×1.25
M	21	24.5	33
N	8	10	12
P	17.5	20	27.5
Q	14	17.5	24
R	11.5	13.5	17
AA	10.5	12	14
AB	12.5	14	16
AC	3	3	3
AD	11	13.5	16.5
AE	12	15	19
AF	R15	R20	R25
AG	23.7°	24.1°	28°
AH	0.7	1.3	0.4
AJ	35.7	41.5	51.9
AK	4	5	6
EA (Nominal × Pitch)	M4×0.7	M5×0.8	M6×1
EB	21	25	30
EC	38	40.5	40.5
ED	40	42.5	44.5
EF	34	36.5	36.5
EG	22.5	25	25
EH	30.5	33	33
DA	AS568-017(90)	AS568-020(90)	AS568-023(90)
DB	Inner Diam. 17.2× Wire Diam. 1.78	Inner Diam. 20.4× Wire Diam. 1.78	Inner Diam. 25.1× Wire Diam. 1.78
DC	AS568-016(90)	AS568-018(90)	AS568-022(90)
DD	AS568-015(90)	AS568-018(90)	AS568-021(90)

● Link Lever Design Dimensions

※ Reference for designing link lever.

● Link lever for TQA0160

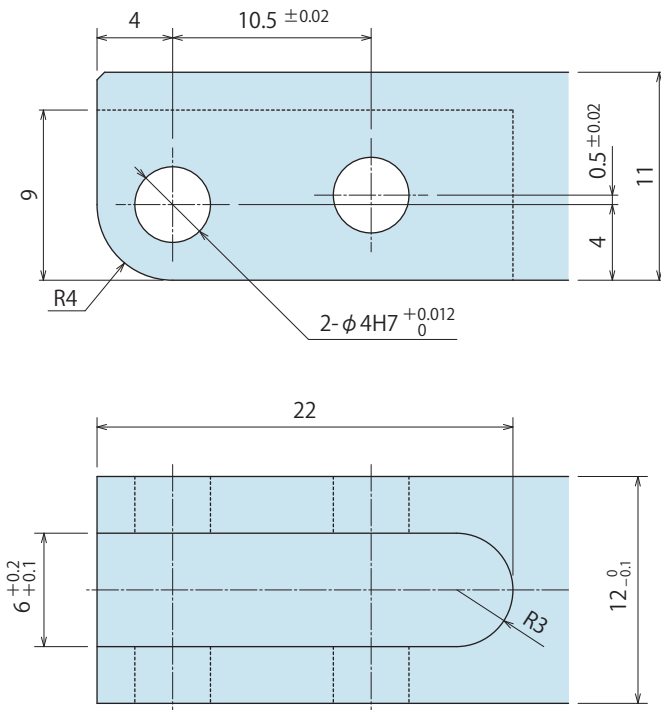

Notes :

1. Please design the link lever length according to the performance curve.
2. If the link lever is not in accordance with the dimensions shown above, performance may be degraded and damage can occur.
3. Use the attached pin (equivalent to $\phi 4 f6$, HRC60) as the lever mounting pin.

● Link lever for TQA0300/TQA0450

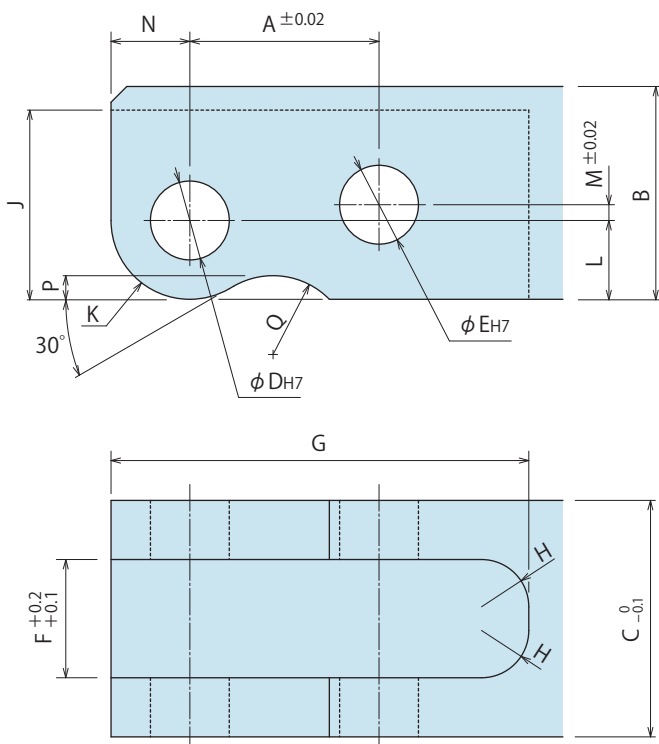

Corresponding Model No.	TQA0300	TQA0450
A	12	14
B	13.5	16.5
C	15	19
D	$5^{+0.012}_0$	$6^{+0.012}_0$
E	$5^{+0.012}_0$	$7^{+0.015}_0$
F	7.5	9.5
G	26.5	32.5
H	R3	R4.5
J	12	15
K	R5	R6
L	5	6
M	1	1.5
N	5	6
P	1.5	2
Q	R5	R6

Notes :

1. Please design the link lever length according to the performance curve.
2. If the link lever is not in accordance with the dimensions shown above, performance may be degraded and damage can occur.
3. Use the attached pin (equivalent to $\phi D f6 / \phi E f6$, HRC60) as the lever mounting pin.

● Cautions

● Notes for Design

1) Check Specifications

- Please use each product according to the specifications.

2) Notes for Circuit Design

- Please read "Notes on Hydraulic Cylinder Speed Control Unit" for proper hydraulic circuit design. Improper circuit design may lead to malfunctions and damages.
- Ensure there is no possibility of supplying hydraulic pressure to the clamp port and the unclamp port simultaneously.

3) Notes for Link Lever Design

- Make sure no force is applied to the piston rod except from the axial direction. The usage like the one shown in the drawing below will apply a large bending stress to the piston rod and must be avoided.

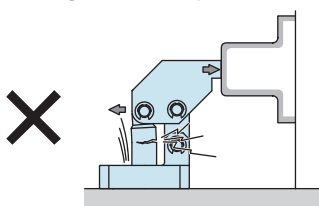

- Offset lever cannot be used. Offset load may damage the product.

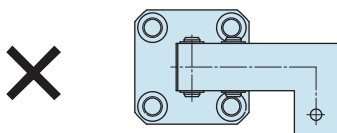

4) Protect the exposed area of the piston rod when using on a welding fixture.

- If spatter attaches to the sliding surface it could lead to malfunction and fluid leakage.

5) When clamping on a sloped surface of the workpiece

- Make sure the clamping surface and the mounting surface of the clamp are parallel.

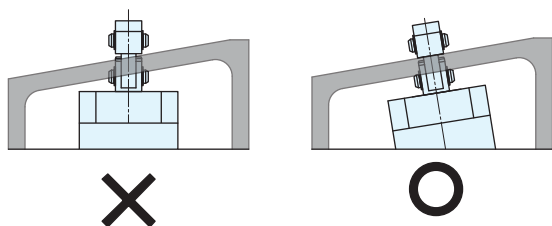

6) When using TQA-J-□

- Make sure to check the notes for design, installation and use on P.5 in case of air sensing with an air sensor.

7) When using in a dry environment.

- The link pin can be dried out. Please grease it periodically.

8) The cartridge cavity of the clamp should be machined as shown in the external dimensions.

The external o-ring may be damaged when it passes through the port on the inner wall of the hole.



● Notes on Hydraulic Cylinder Speed Control Unit

Please pay attention to the cautions below.



Design the hydraulic circuit for controlling the action speed of hydraulic cylinder. Improper circuit design may lead to malfunctions and damages. Please review the circuit design in advance.

● Flow Control Circuit for Double Acting Cylinder

In the case of controlling the speed of TQA, both clamp side and unclamp side should be meter-in circuit. If meter-out circuit is used, abnormal high pressure is created, which causes oil leakage and damage.

【Meter-in Circuit】

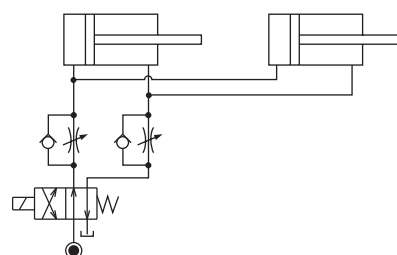

Cautions

Installation Notes

- 1) Check the Usable Fluid
 - Please use the appropriate fluid by referring to the Hydraulic Fluid List.
- 2) Procedure before Piping
 - The pipeline, piping connector and fixture circuits should be cleaned by thorough flushing.
 - The dust and cutting chips in the circuit may lead to fluid leakage and malfunction.
 - There is no filter provided with Kosmek's product except for a part of valves which prevent contamination in the circuit.
- 3) Applying Sealing Tape
 - Wrap with tape 1 to 2 times following the screw direction.
 - Pieces of the sealing tape can lead to oil leakage and malfunction.
 - Please implement piping construction in a clear environment to prevent anything getting in products.
- 4) Be careful not to damage the O-ring.
 - If installed in a dry state, the external o-ring may be damaged. Apply an appropriate amount of grease to the cartridge cavity to prevent the external O-ring from being caught. Stable detection may not be possible if the grease remains inside the clamp.

Installation / Removal of the Product

- For installation, use four hexagonal socket bolts (with tensile strength of 12.9) and tighten them with the torque shown in the table below. Tightening with greater torque than recommended can dent the seating surface or break the bolt.

Model No.	Mounting Bolt Size	Tightening Torque (N·m)
TQA0160	M4×0.7	3.2
TQA0300	M5×0.8	6.3
TQA0450	M6×1	10

- For removal, use a jacking bolt (mounting bolt hole) shown in the table below to avoid damaging the fixing threads. The following image shows a case where a parallel pin (set screw) is inserted in the screw hole to prevent damage to the fixing thread.

Model No.	Jacking Bolt Size
TQA0160	M5×0.8
TQA0300	M6×1
TQA0450	M8×1.25

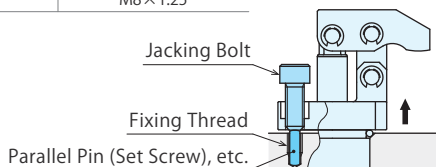

6) Trial Operation Method

- There is a lot of air in the circuit just after installation. If high pressure with large flow rate is supplied under such condition, action time will be extremely fast leading to severe damage on a clamp. Make sure to perform running-in operation with low pressure with small flow rate and bleed the air in the circuit.

7) Speed Adjustment

- Adjust the speed so that the total operating time for both clamp and unclamp is 0.5 seconds or more. If the clamp operates too fast, the parts will be worn out, leading to premature damage and ultimately complete equipment failure.

- Please make sure to release air from the circuit before adjusting speed. It will be difficult to adjust the speed accurately with air mixed in the circuit.
- Turn the speed control valve gradually from the low-speed side (small flow) to the high-speed side (large flow) to adjust the speed.

8) Air Bleeding of the Hydraulic Circuit

- If the hydraulic circuit has excessive air, the action time may become very long. If air enters the circuit after connecting the hydraulic port or under the condition of no air in the oil tank, please perform the following steps.

- ① Reduce hydraulic pressure to less than 2MPa.
- ② Loosen the cap nut of pipe fitting closest to the clamp, cylinder, work support, etc. by one full turn.
- ③ Shake the pipeline to loosen the outlet of pipe fitting. Hydraulic fluid mixed with air comes out.

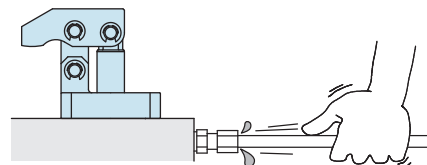

- ④ Tighten the cap nut after air bleeding.
- ⑤ It is more effective to release air at the highest point inside the circuit or at the end of the circuit.

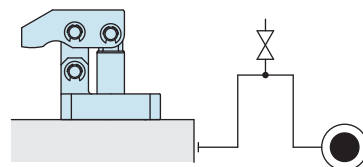

9) Checking Looseness and Retightening

- At the beginning of the product installation, the bolt may be tightened lightly. Check the looseness and re-tighten as required.

10) Installation / Removal of the Link Lever

- When inserting the link pin, do not hit the pin directly with a hammer. When using a hammer to insert the pin, always use a cover plate with a smaller diameter than the spring ring groove on the pin.

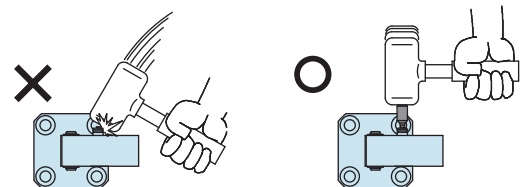

Hydraulic Fluid List

Manufacturer	ISO Viscosity Grade ISO-VG-32	
	Anti-Wear Hydraulic Oil	Multi-Purpose Hydraulic Oil
Showa Shell Sekiyu	Tellus S2 M 32	Morlina S2 B 32
Idemitsu Kosan	Daphne Hydraulic Fluid 32	Daphne Super Multi Oil 32
JX Nippon Oil & Energy	Super Hyrando 32	Super Mulpus DX 32
Cosmo Oil	Cosmo Hydro AW32	Cosmo New Mighty Super 32
ExxonMobil	Mobil DTE 24	Mobil DTE 24 Light
Matsumura Oil	Hydol AW-32	
Castrol	Hyspin AWS 32	

Note : Please contact manufacturers when customers require products in the list above.

● Notes on Handling

- 1) It should be operated by qualified personnel.
 - The hydraulic machine and air compressor should be operated and maintained by qualified personnel.
- 2) Do not operate or remove the product unless the safety protocols are ensured.
 - ① The machine and equipment can only be inspected or prepared when it is confirmed that the safety devices are in place.
 - ② Before the product is removed, make sure that the above-mentioned safety devices are in place. Shut off the pressure and power source, and make sure no pressure exists in the hydraulic and air circuits.
 - ③ After stopping the product, do not remove until the temperature drops.
 - ④ Make sure there is no abnormality in the bolts and respective parts before restarting the machine or equipment.
- 3) Do not touch the clamp while it is working.
Otherwise, your hands may be injured due to clinching.



- 4) Do not disassemble or modify.
 - If the equipment is taken apart or modified, the warranty will be voided even within the warranty period.
- 5) Do not use deformed snap rings.
 - When installing or replacing a lever, do not use open-mouthed or deformed snap rings for link pin. Snap rings may not be attached properly.

● Warranty

- 1) Warranty Period
 - The product warranty period is 18 months from shipment from our factory or 12 months from initial use, whichever is earlier.
- 2) Warranty Scope
 - If the product is damaged or malfunctions during the warranty period due to faulty design, materials or workmanship, we will replace or repair the defective part at our expense.
Defects or failures caused by the following are not covered.
 - ① If the stipulated maintenance and inspection are not carried out.
 - ② If the product is used while it is not suitable for use based on the operator's judgment, resulting in defect.
 - ③ If it is used or operated in an inappropriate way by the operator. (Including damage caused by the misconduct of the third party.)
 - ④ If the defect is caused by reasons other than our responsibility.
 - ⑤ If repair or modifications are carried out by anyone other than Kosmek, or without our approval and confirmation, it will void warranty.
 - ⑥ Others caused by natural disasters or calamities not attributable to our company.
 - ⑦ Parts or replacement expenses due to parts consumption and deterioration. (Such as rubber, plastic, seal material and some electric components.)

Damages excluding from direct result of a product defect shall be excluded from the warranty.

● Maintenance and Inspection

- 1) Removal of the Product and Shut-off of Pressure Source
 - Before the product is removed, make sure that safety devices and preventive devices are in place. Shut off the pressure and power source, and make sure no pressure exists in the hydraulic and air circuits.
 - Make sure there is no abnormality in the bolts and respective parts before restarting.
- 2) Regularly clean the area around the piston rod and the link.
 - If it is used when the surface is contaminated with dirt, it may lead to packing seal damage, malfunctioning and fluid leakage.

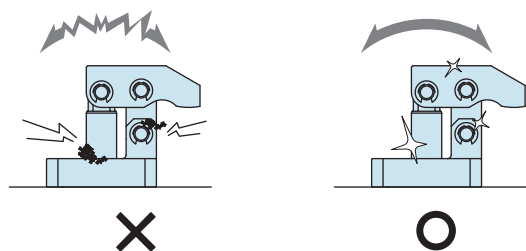

- 3) If disconnecting by couplers, air bleeding should be carried out on a regular basis to avoid air mixed in the circuit.
- 4) Regularly check the condition of the air sensor settings.
Due to wear of internal components, the condition may change from the initial setting. Regularly check and adjust as necessary.
- 5) Regularly tighten pipes and mounting bolts to ensure proper use.
- 6) Make sure the hydraulic fluid has not deteriorated.
- 7) Make sure there is a smooth action without an irregular noise.
 - Especially when it is restarted after left unused for a long period, make sure it can be operated correctly.
- 8) The products should be stored in the cool and dark place without direct sunshine or moisture.
- 9) Please contact us for overhaul and repair.



KOSMEK LTD.

▶ <https://www.kosmek.com/>

HEAD OFFICE 1-5, 2-chome, Murotani, Nishi-ku, Kobe-city, Hyogo, Japan 651-2241
TEL.+81-78-991-5162 FAX.+81-78-991-8787

United States of America SUBSIDIARY	KOSMEK (USA) LTD. 650 Springer Drive, Lombard, IL 60148 USA TEL. +1-630-620-7650 FAX. +1-630-620-9015
MEXICO BRANCH OFFICE	KOSMEK USA MEXICO BRANCH OFFICE Av. Loma Pinal de Amoles 320-piso PH oficina 504 interior 13, Vista Dorada, 76060 Santiago de Querétaro, Qro. Mexico TEL. +52-442-851-1377
EUROPE SUBSIDIARY	KOSMEK EUROPE GmbH Schleppeplatz 2 9020 Klagenfurt am Wörthersee Austria TEL. +43-463-287587 FAX. +43-463-287587-20
CHINA SUBSIDIARY	KOSMEK (CHINA) LTD. Room601, RIVERSIDE PYRAMID No.55, Lane21, Pusan Rd, Pudong Shanghai 200125, China TEL. +86-21-54253000
INDIA BRANCH	KOSMEK LTD. - INDIA 4A/Old No:649, Ground Floor, 4th D cross, MM Layout, Kavalbyrasandra, RT Nagar, Bangalore -560032 India TEL.+91-9880561695
THAILAND REPRESENTATIVE OFFICE	KOSMEK Thailand Representation Office No.139, Blue Chips Building, 4th Floor, Room No.422, Soi Sukhumvit 63 (Thong Lor 10), Sukhumvit Road, Khlong Tan Nuea, Wattana, Bangkok 10110, Thailand TEL. +66(0)2-059-2010

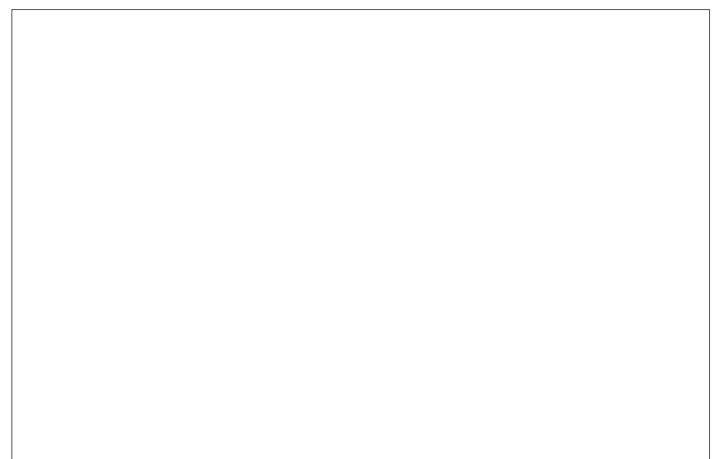

- For Further Information on Unlisted Specifications and Sizes, Please call us.
- Specifications in this Leaflet are Subject to Change without Notice.

