

35MPa

Single Acting

New Hydraulic Single Acting Work Support



Model TNE

New Options Available

**Spring Advance model, Long Stroke model
and Air Sensing Option**

Hydraulic Work Support

Single Action • High Pressure Model

Model TNE



NEW Options : Spring Advance model, Long Stroke model and Air Sensing option

Strong Support from opposite side when load is applied

Compared to our conventional product, model TNC, it achieves up to twice the support capacity!

Work support eliminates chattering while machining and prevents deformation by the cutting load.

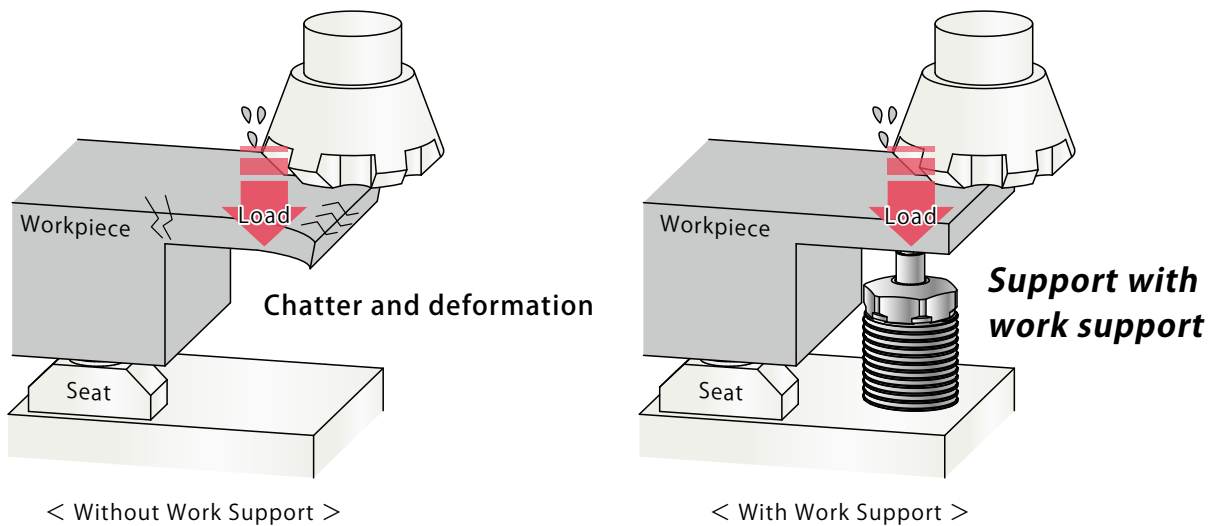

Application Examples

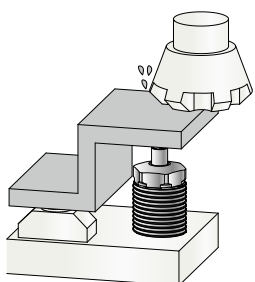

To avoid chattering during machining of thin-walled sections

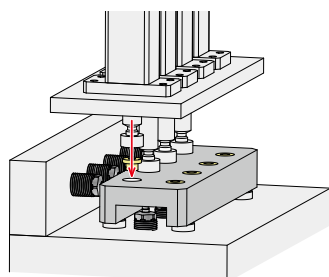

To support a press-fit machine

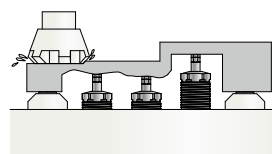

To support a workpiece with different heights

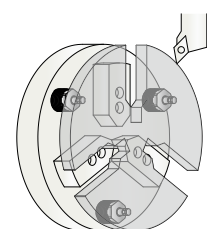

To avoid the radial chatter on lathe machining. ※Please contact us.

Cross Section * This is a simplified drawing. Actual components are different.

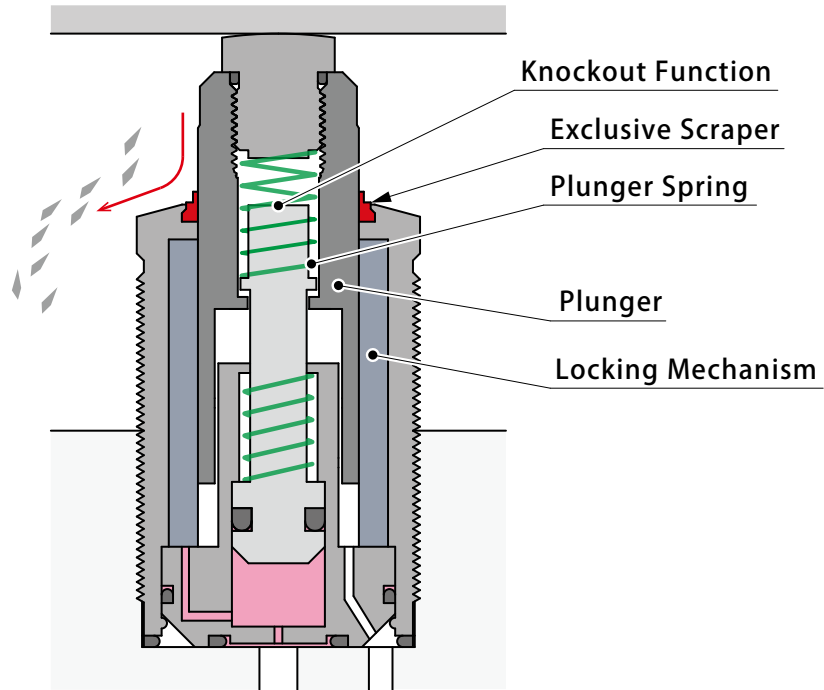

Compact yet Powerful

The support force has increased by about 1.5 to 2 times compared to our conventional product (model TNC) of the same size. It contributes to the downsizing of equipment.

Knockout Function Utility Model Registration

After a prolonged shutdown, if the plunger cannot operate due to adhesion caused by dried sludge, etc., the knockout mechanism releases the adhesion.

High Rigidity with Large Diameter Plunger

Displacement remains minimal even under heavy cutting and high loads, enabling improved machining accuracy.

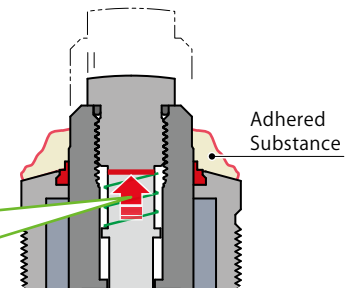

Air Sensing Option

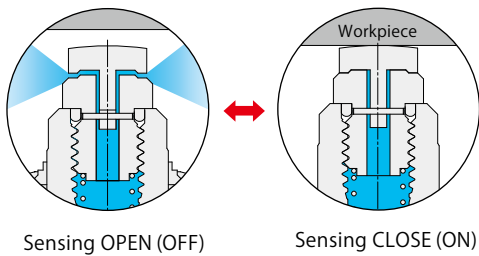

Superior Environmental Durability

The work support can be used in various environments with the exclusive scraper to prevent the accumulation of dust such as cutting chips and the knockout function to release adherence after a long-time machine stop.

Air Purging Possible

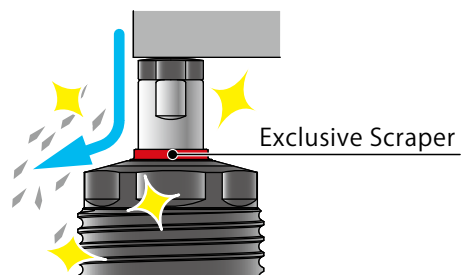
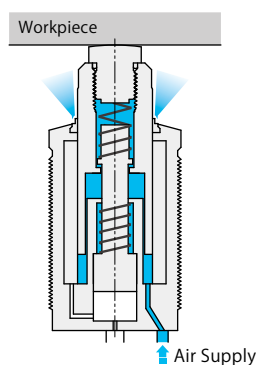

● Action Description

● Hydraulic Advance Model : TNE / TNE-Q

Operation

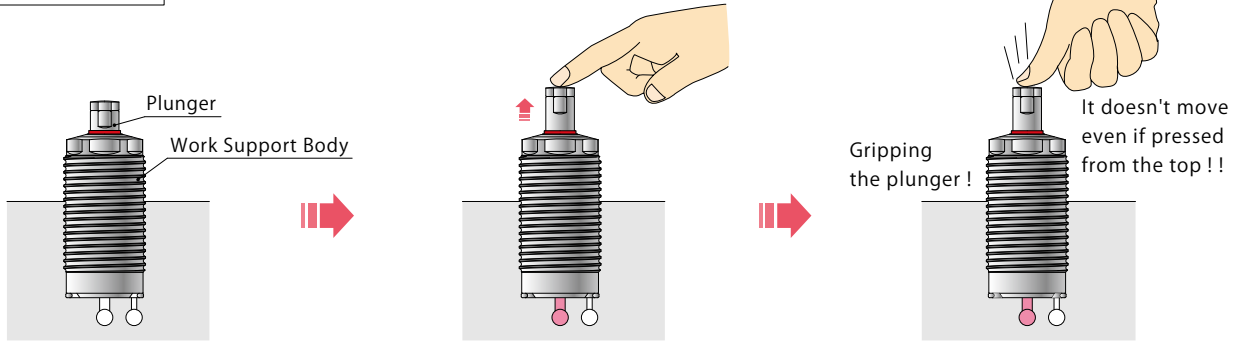

Cross Section

* Simplified drawing. The actual components are different.

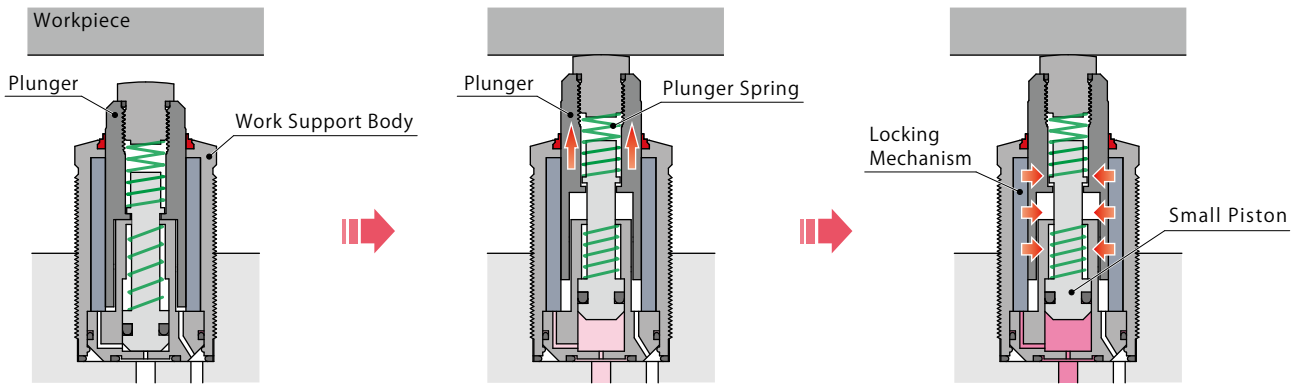

Hydraulic Pressure : OFF

The state of plunger down.

**Hydraulic Pressure : ON
(Pressure Rising)**

The plunger lifts up with hydraulic pressure and stops after touching the workpiece.

※ The load applied to the workpiece is only the plunger spring force.

**Hydraulic Pressure : ON
(Pressurization Completed)**

When the small piston is fully stroked, pressure is applied to the locking mechanism, securing the plunger. Once secured, the plunger will not move downward even if pressed from above.

● Air Sensing Option : TNE-M / TNE-M-E / TNE-M-Q

Available to check action by connecting the air sensor at air port and then detecting differential pressure.

Please refer to the air sensor page for further details.

● Spring Advance Model : TNE-E / TNE-EQ

Operation

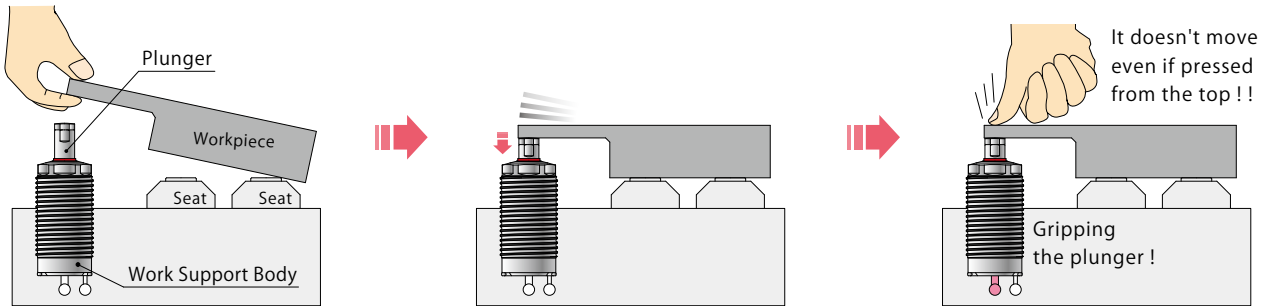

Cross Section

* Simplified drawing. The actual components are different.

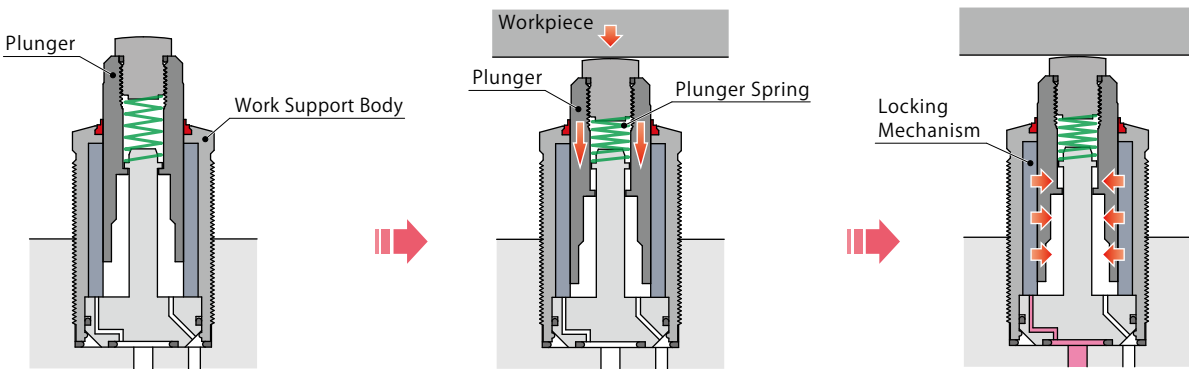

Hydraulic Pressure : OFF

The state of plunger up.

Hydraulic Pressure : OFF

The plunger descends according to the workpiece weight and stops at the seating (Prepared by Customer).

※ The load applied to the workpiece is only the plunger spring force.

The workpiece may be lifted up, if the plunger spring force is higher than the workpiece weight.

Hydraulic Pressure : ON
(Pressurization Completed)

When hydraulic pressure rises inside of the main body, the locking mechanism allows the collet to grip the plunger. After gripping, the plunger does not go down even if pressed from above.

● Plunger is locked where it touches the workpiece within the stroke range.

Without Work Support

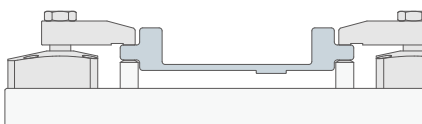

With Work Support

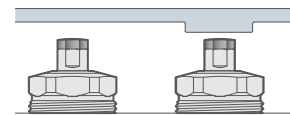
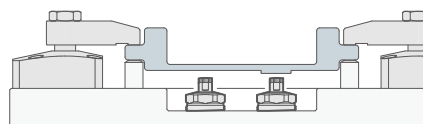

Before plunger is lifted up

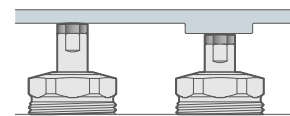
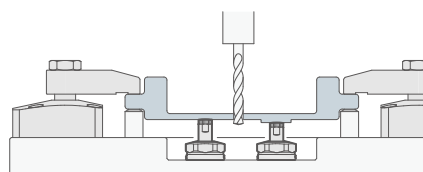
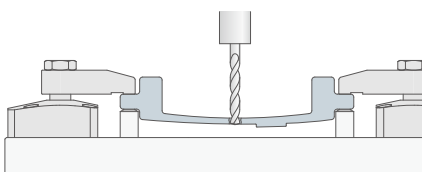

Locked after touching workpiece

Bending

No Bending!!

Model No. Indication

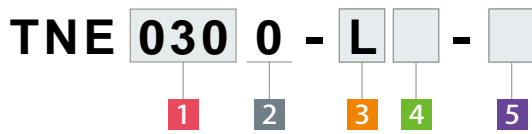

1 Body Size

- 026 : External Thread M26×1.5
- 030 : External Thread M30×1.5
- 036 : External Thread M36×1.5
- 045 : External Thread M45×1.5

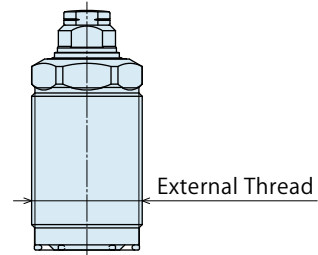

2 Design No.

0 : Revision Number

3 Plunger Spring Force

- L : Low Spring Force
- H : High Spring Force
- Blank : For 5 Option Q, EQ

4 Plunger Action Confirmation

- Blank : None (Standard)
- M : Air Sensing Option^{※1}

5 Option

- Blank : Hydraulic Advance Model (Standard)
- Q : Hydraulic Advance Long Stroke Model^{※1}
- E : Spring Advance Model
- EQ : Spring Advance Long Stroke Model

		● = Available Option			
		M26×1.5	M30×1.5	M36×1.5	M45×1.5
4	Plunger Action Confirmation	TNE 0260	TNE 0300	TNE 0360	TNE 0450
5	Option				
	Blank	●	●	●	●
	Q	●	●	●	●
	E	●	●	●	●
	EQ	●	●	●	●
	M	●	●	●	●
	M-Q	●	●	●	●
	M-E	●	●	●	●
	M-EQ	●	●	●	●

Note :

※1. Please contact us for detailed specification and external dimensions for the combination of 4 M : Air Sensing Option and 5 Q : Long Stroke Model.

Specifications

Work Support

Accessory

Option 5 Blank / E

Model No.	TNE0260-□		TNE0300-□		TNE0360-□		TNE0450-□		
	TNE0260-□M		TNE0300-□M		TNE0360-□M		TNE0450-□M		
		TNE0260-□-E		TNE0300-□-E		TNE0360-□-E		TNE0450-□-E	
		TNE0260-□M-E		TNE0300-□M-E		TNE0360-□M-E		TNE0450-□M-E	
Support Force at 35MPa	kN	9.4		11.5		17.9		24.8	
Support Force (Calculation Formula) ^{※2}	kN	0.30×P-1.04		0.36×P-1.08		0.56×P-1.68		0.78×P-2.33	
Plunger Stroke	mm	6.5		8.0		10		12	
Effective Stroke	mm	5 Option Blank		7.5		9.5		11.5	
Cylinder Capacity		5 Option Blank		0.9		1.6		2.1	
	cm ³	5 Option E		0.3		0.5		0.8	
Plunger		L : Low Spring Force		6.6 ~ 9.7		9.3 ~ 14.6		11.8 ~ 18.6	
Spring Force ^{※3}	N	H : High Spring Force		9.0 ~ 13.5		12.1 ~ 21.9		15.4 ~ 33.4	
Max. Operating Pressure	MPa	35							
Min. Operating Pressure	MPa	7							
Operating Temperature	°C	0 ~ 70							
Usable Fluid		General Hydraulic Oil equivalent to ISO-VG-32							
Weight	kg	0.15		0.2		0.4		0.7	

Option 5 Q / EQ

Model No.	TNE0260-Q		TNE0300-Q		TNE0360-Q		TNE0450-Q		
	TNE0260-EQ		TNE0300-EQ		TNE0360-EQ		TNE0450-EQ		
Support Force at 35MPa	kN	9.4		11.5		17.9		24.8	
Support Force (Calculation Formula) ^{※2}	kN	0.30×P-1.04		0.36×P-1.08		0.56×P-1.68		0.78×P-2.33	
Plunger Stroke	mm	13		16		20		24	
Effective Stroke	mm	5 Option Q		15.5		19.5		23.5	
Cylinder Capacity		5 Option Q		1.5		2.7		3.5	
	cm ³	5 Option EQ		0.3		0.5		0.8	
Plunger Spring Force ^{※3}	N	7.4 ~ 12.9		9.1 ~ 16.3		12.1 ~ 26.7		15.4 ~ 27.8	
Max. Operating Pressure	MPa	35							
Min. Operating Pressure	MPa	7							
Operating Temperature	°C	0 ~ 70							
Usable Fluid		General Hydraulic Oil equivalent to ISO-VG-32							
Weight		5 Option Q		0.3		0.55		1.1	
	kg	5 Option EQ		0.2		0.45		0.8	

Notes: ※2. P in the formula for support force indicates the hydraulic pressure (MPa).

※3. The plunger spring force indicates the spring design value. It may vary depending on sliding resistance of the plunger and characteristic of the spring, etc. Please read it as a reference value of workpiece contact force. For the workpiece contact force of 4 M: Air sensing option, refer to the air sensing option on P.19.

● Performance Curve (TNE-□ : Hydraulic Advance Model / TNE-□-E : Spring Advance Model)

Applicable Model

TNE **030** **0** - **LH** - **Blank E**

1 Body Size **5** Option : Blank, E

■ Support Force Graph ※ This graph shows the support force under static load condition.

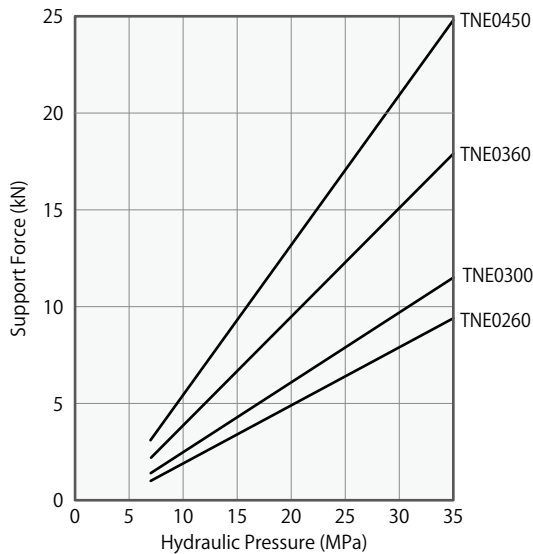

Model No.	Support Force (kN)			
	TNE0260-□	TNE0300-□	TNE0360-□	TNE0450-□
Hyd. Pressure (MPa)	TNE0260-□-E	TNE0300-□-E	TNE0360-□-E	TNE0450-□-E
35	9.4	11.5	17.9	24.8
28	7.3	9.0	14.0	19.4
21	5.2	6.5	10.1	14.0
14	3.1	4.0	6.1	8.5
7	1.0	1.4	2.2	3.1
Support Force Formula ^{※1} kN	$0.30 \times P - 1.04$	$0.36 \times P - 1.08$	$0.56 \times P - 1.68$	$0.78 \times P - 2.33$

Note : ※ 1. P: Operating Hydraulic Pressure (MPa)

■ Load / Displacement Graph ※ This graph shows the static load-displacement of a single work support at supply hydraulic pressure 35MPa. (Not including the displacement of the workpiece side due to unevenness at ★ mark and surrounding clamps.)

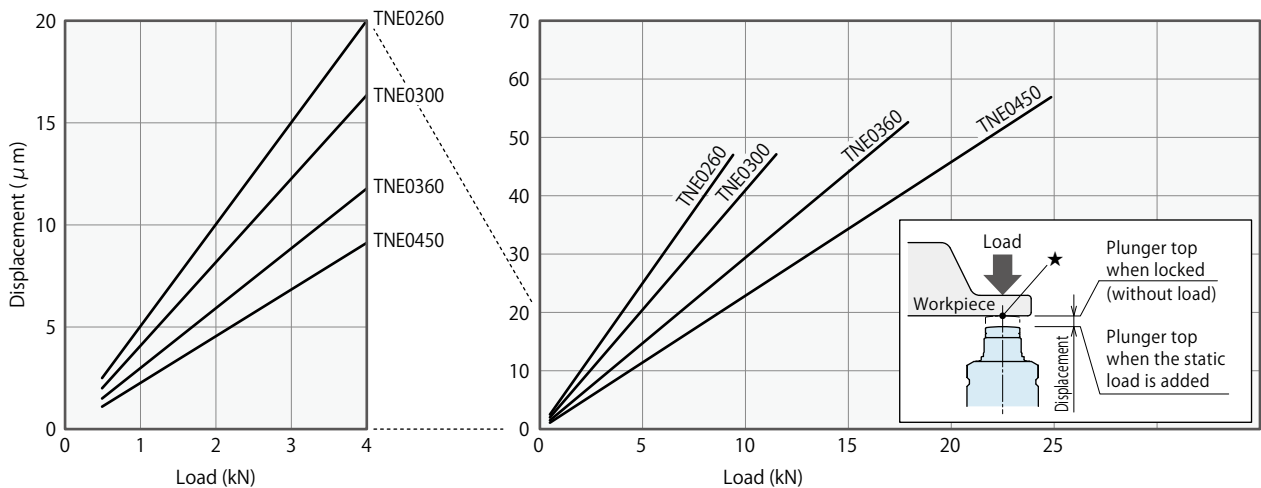

● Performance Curve (TNE-□M : Hydraulic Advance Air Sensing Option / TNE-□M-E : Spring Advance Air Sensing Option)

Applicable Model

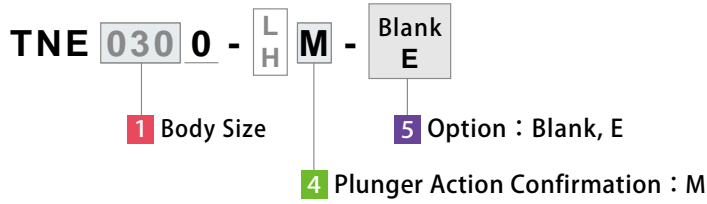

■ Support Force Graph ※ This graph shows the support force under static load condition.

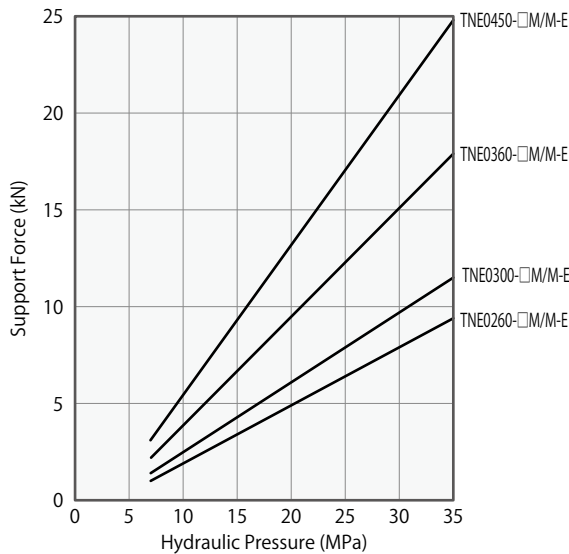

Model No.	Support Force (kN)			
	TNE0260-□M	TNE0300-□M	TNE0360-□M	TNE0450-□M
Hyd. Pressure (MPa)	TNE0260-□M-E	TNE0300-□M-E	TNE0360-□M-E	TNE0450-□M-E
35	9.4	11.5	17.9	24.8
28	7.3	9.0	14.0	19.4
21	5.2	6.5	10.1	14.0
14	3.1	4.0	6.1	8.5
7	1.0	1.4	2.2	3.1
Support Force Formula ^{※1} kN	$0.30 \times P - 1.04$	$0.36 \times P - 1.08$	$0.56 \times P - 1.68$	$0.78 \times P - 2.33$

Note : ※ 1. P: Operating Hydraulic Pressure (MPa)

■ Load / Displacement Graph ※ This graph shows the static load-displacement of a single work support at supply hydraulic pressure 35MPa. (Not including the displacement of the workpiece side due to unevenness at ★ mark and surrounding clamps.)

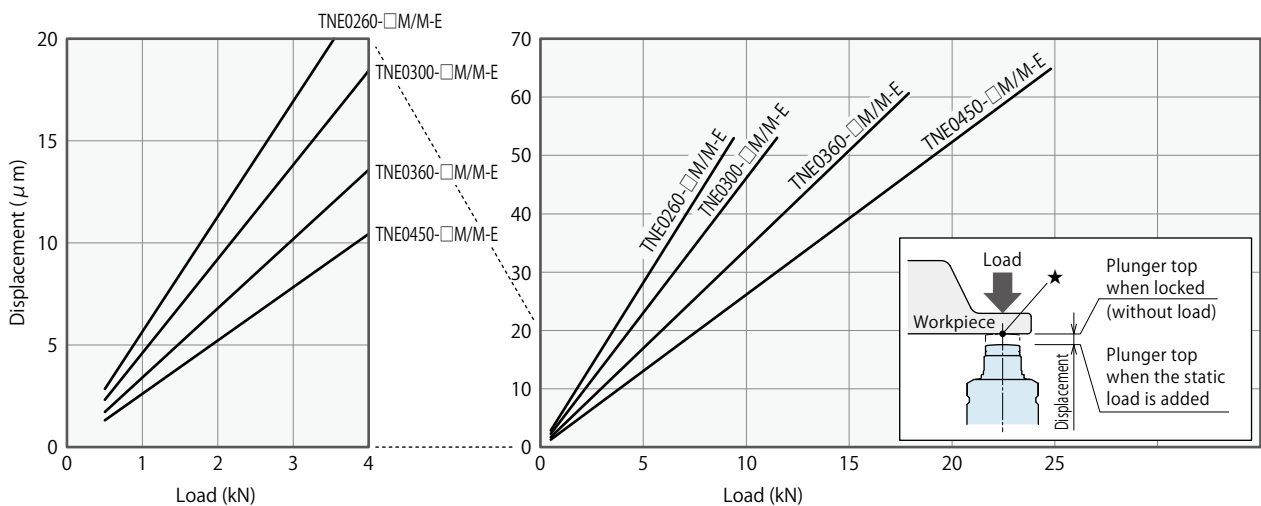

※ The displacement of TNE-□M / TNE-□M-E : Air Sensing Option is larger than that of TNE/TNE-E : Standard Model.
 ※ Contact us for TNE-M-Q / TNE-M-EQ.

 **MEMO**

Work Support

Accessory

External Dimensions

※ This drawing shows the released state of TNE-□ (before the plunger is lifted).

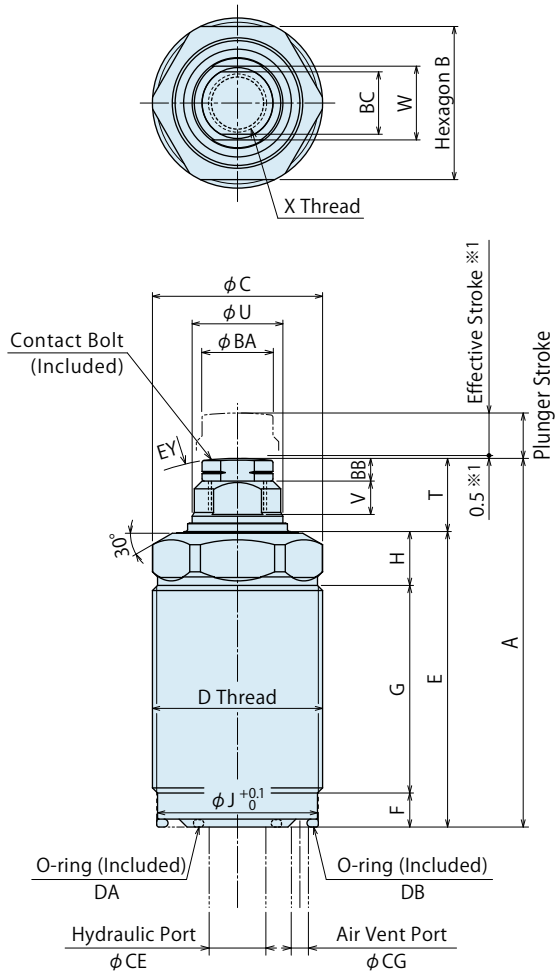

Machining Dimensions of Mounting Area

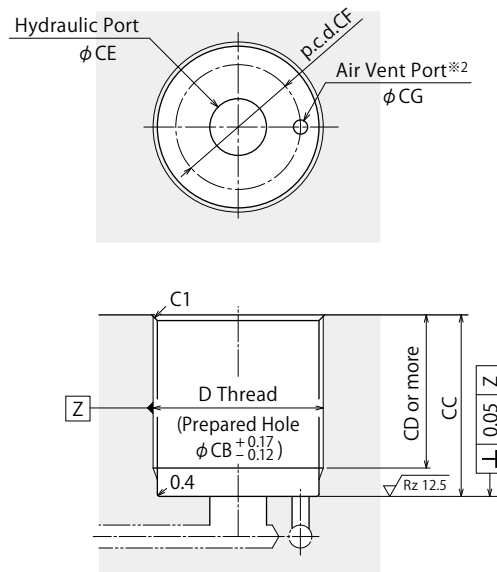

Note :

※2. The vent port needs to be machined in an open air environment without the presence of coolant, etc. to avoid any internal contamination. (Refer to P.23 : Appropriate Measures for the Air Vent Port.)

Note :

※1. When the work support touches a workpiece within short stroke range, up to 0.5mm from the plunger retract-end, a force which is larger than the plunger spring force will be applied to the workpiece. Please use the work support within the effective stroke range.

Contact Bolt Design Dimensions

※Reference for designing a contact bolt (attachment) by customer other than the included contact bolt.

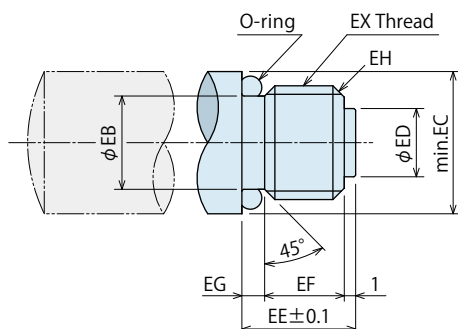

Model No. Indication

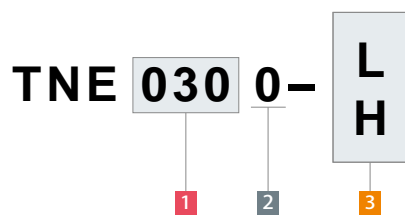

(Format Example : TNE0300-L)

- 1 Body Size
- 2 Design No.
- 3 Plunger Spring Force
- 4 Plunger Action Confirmation (Blank)
- 5 Option (Blank)

Work Support

Accessory

External Dimensions and Machining Dimensions for Mounting (mm)

Model No.	TNE0260-□	TNE0300-□	TNE0360-□	TNE0450-□
Plunger Stroke	6.5	8	10	12
Effective Stroke	6.0	7.5	9.5	11.5
A	60	65	76.5	88
B	24	27	32	41
C	26	30	36	45
D (Nominal×Pitch)	M26×1.5	M30×1.5	M36×1.5	M45×1.5
E	47.1	52.1	59.6	69.2
F	6	6	7	7
G	32.6	36.6	43.1	51.7
H	8.5	9.5	9.5	10.5
J	24.2	28.2	34.2	43.2
T	12.9	12.9	16.9	18.8
U	14	16	20	25
V	6	6	8	8.5
W	12	13	17	21
X (Nominal×Pitch×Depth)	M10×1.5×11	M10×1.5×11	M12×1.75×13	M12×1.75×13
BA	12.5	12.5	16.5	16.5
BB	4	4	6	6
BC	11	11	14	14
CB	24.5	28.5	34.5	43.5
CC	15 ~ 38	15 ~ 41	15 ~ 49	18 ~ 57
CD	CC-5	CC-5	CC-6	CC-6
CE	max. 8	max. 10	max. 10	max. 12
CF	p.c.d. 19	p.c.d. 22	p.c.d. 26	p.c.d. 30
CG	max. 2.5	max. 3	max. 5	max. 6
DA	AS568-013(90)	AS568-014(90)	AS568-015(90)	AS568-017(90)
DB	AS568-020(90)	AS568-022(90)	AS568-026(90)	AS568-030(90)
EY	SR50	SR50	SR80	SR80
Tightening Torque for Main Body ^{※3}	31.5 N·m	50 N·m	63 N·m	80 N·m

Note : ^{※3}. Please follow the tightening torque in the list when mounting Work Support.

Excessive tightening torque causes deformation of the product resulting in malfunction.

Insufficient tightening torque causes looseness of the product resulting in damage of the O-ring and oil leakage.

Contact Bolt Design Dimensions

[※]Reference for designing a contact bolt (attachment) by customer other than the included contact bolt.

Corresponding Model No.	TNE0260-□	TNE0300-□	TNE0360-□	TNE0450-□
EB	7.4	7.4	9.4	9.4
EC	12.5	12.5	16.5	16.5
ED	6	6	7.5	7.5
EE	10	10	12	12
EF	7.3	7.3	8.7	8.7
EG	1.7	1.7	2.3	2.3
EH	C1	C1	C1.2	C1.2
EX	M10	M10	M12	M12
O-ring	AS568-010(70)	AS568-010(70)	AS568-012(70)	AS568-012(70)
Tightening Torque for Contact Bolt	16N·m	16N·m	40N·m	40N·m
Reference	Material	S45C		
	Quenching Hardness	HRC50~55		
	Surface Finishing	Alkaline Blackening		

Notes :

1. It should be designed according to the weight of contact bolt and the plunger spring force.
2. If using a contact bolt with different dimensions than those shown above, spring force will be different from the values on catalog, and the plunger spring will be damaged leading to malfunctions.

External Dimensions

※ This drawing shows the released state of TNE-Q (before the plunger is lifted).

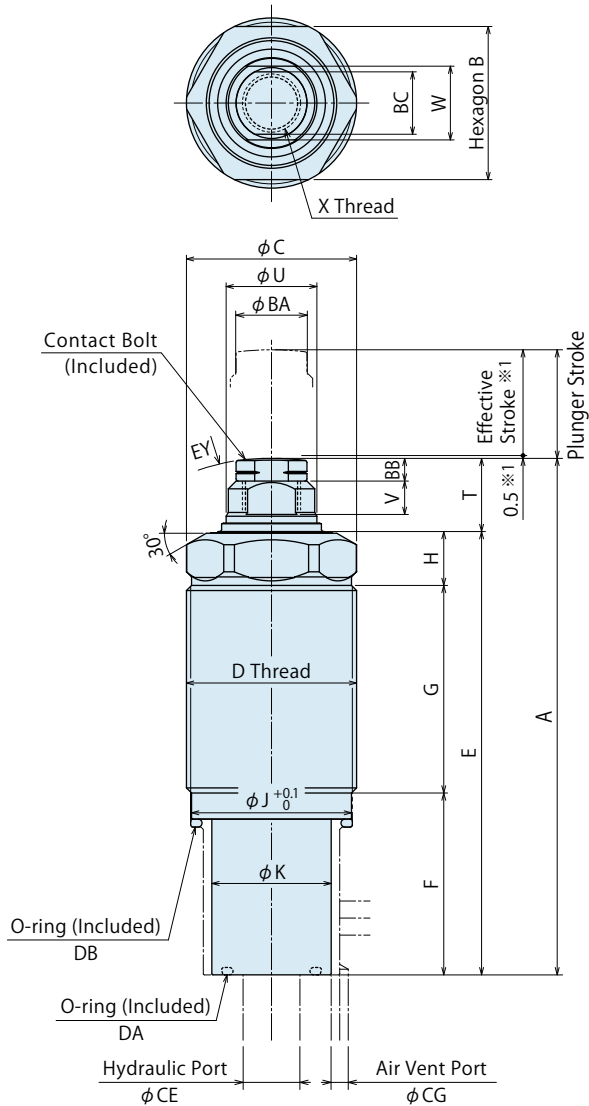

Note :

- ※1. When the work support touches a workpiece within short stroke range, up to 0.5mm from the plunger retract-end, a force which is larger than the plunger spring force will be applied to the workpiece. Please use the work support within the effective stroke range.

Machining Dimensions of Mounting Area

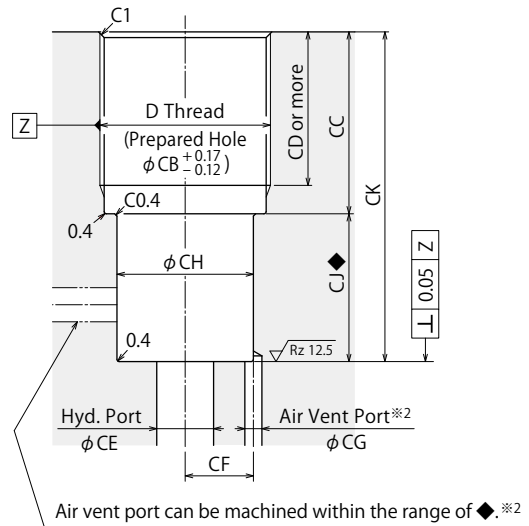

Note :

- ※2. The vent port needs to be machined in an open air environment without the presence of coolant, etc. to avoid any internal contamination. (Refer to P.23 : Appropriate Measures for the Air Vent Port.)

Contact Bolt Design Dimensions

※Reference for designing a contact bolt (attachment) by customer other than the included contact bolt.

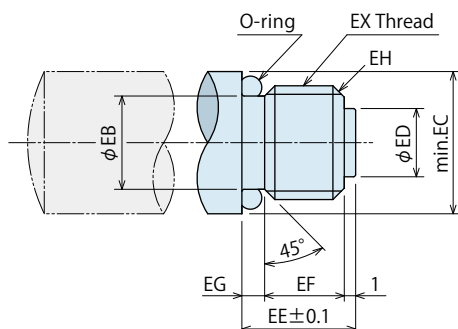

Model No. Indication

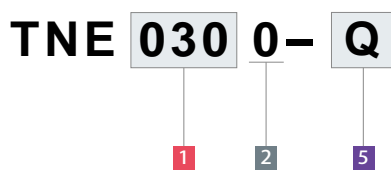

(Format Example : TNE0300-Q)

- 1 Body Size
- 2 Design No.
- 3 Plunger Spring Force (Blank)
- 4 Plunger Action Confirmation (Blank)
- 5 Option : Q

External Dimensions and Machining Dimensions for Mounting ^(mm)

Model No.	TNE0260-Q	TNE0300-Q	TNE0360-Q	TNE0450-Q
Plunger Stroke	13	16	20	24
Effective Stroke	12.5	15.5	19.5	23.5
A	83.5	95	112	137
B	24	27	32	41
C	26	30	36	45
D (Nominal×Pitch)	M26×1.5	M30×1.5	M36×1.5	M45×1.5
E	70.6	82.1	95.1	118.2
F	25.5	32	42.5	56
G	36.6	40.6	43.1	51.7
H	8.5	9.5	9.5	10.5
J	24.2	28.2	34.2	43.2
K	18.5	21	29	36
T	12.9	12.9	16.9	18.8
U	14	16	20	25
V	6	6	8	8.5
W	12	13	17	21
X (Nominal×Pitch×Depth)	M10×1.5×11	M10×1.5×11	M12×1.75×13	M12×1.75×13
BA	12.5	12.5	16.5	16.5
BB	4	4	6	6
BC	11	11	14	14
CB	24.5	28.5	34.5	43.5
CC	19 ~ 42	19 ~ 45	15 ~ 49	18 ~ 57
CD	CC-5	CC-5	CC-6	CC-6
CE	max. 8	max. 10	max. 10	max. 12
CF	10	12	13	15
CG	max. 2	max. 3	max. 3	max. 5
CH	20	24	30	39
CJ	19.5	26	35.5	49
CK	CC + 19.5	CC + 26	CC + 35.5	CC + 49
DA	AS568-014(90)	AS568-015(90)	AS568-015(90)	AS568-017(90)
DB	AS568-020(90)	AS568-022(90)	AS568-026(90)	AS568-030(90)
EY	SR50	SR50	SR80	SR80
Tightening Torque for Main Body ※3	31.5 N·m	50 N·m	63 N·m	80 N·m

Note : ※3. Please follow the tightening torque in the list when mounting Work Support.

Excessive tightening torque causes deformation of the product resulting in malfunction.

Insufficient tightening torque causes looseness of the product resulting in damage of the O-ring and oil leakage.

Contact Bolt Design Dimensions

※Reference for designing a contact bolt (attachment) by customer other than the included contact bolt.

Corresponding Model No.	TNE0260-Q	TNE0300-Q	TNE0360-Q	TNE0450-Q
EB	7.4	7.4	9.4	9.4
EC	12.5	12.5	16.5	16.5
ED	6	6	7.5	7.5
EE	10	10	12	12
EF	7.3	7.3	8.7	8.7
EG	1.7	1.7	2.3	2.3
EH	C1	C1	C1.2	C1.2
EX	M10	M10	M12	M12
O-ring	AS568-010(70)	AS568-010(70)	AS568-012(70)	AS568-012(70)
Tightening Torque for Contact Bolt	16N·m	16N·m	40N·m	40N·m
Reference	Material	S45C		
	Quenching Hardness	HRC50~55		
	Surface Finishing	Alkaline Blackening		

Notes :

1. It should be designed according to the weight of contact bolt and the plunger spring force.
2. If using a contact bolt with different dimensions than those shown above, spring force will be different from the values on catalog, and the plunger spring will be damaged leading to malfunctions.

External Dimensions

※ This drawing shows the released state of TNE-□-E/EQ (when the plunger is lifted).

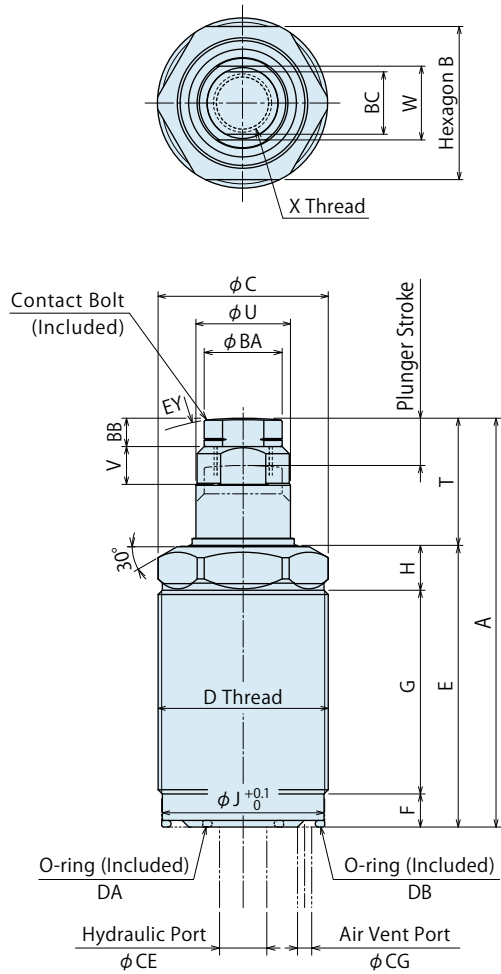

Machining Dimensions of Mounting Area

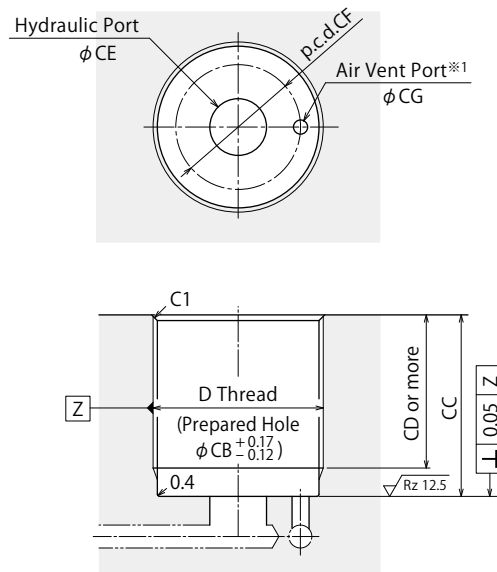

Note:

※1. The vent port needs to be machined in an open air environment without the presence of coolant, etc. to avoid any internal contamination. (Refer to P.23 : Appropriate Measures for the Air Vent Port.)

Contact Bolt Design Dimensions

※Reference for designing a contact bolt (attachment) by customer other than the included contact bolt.

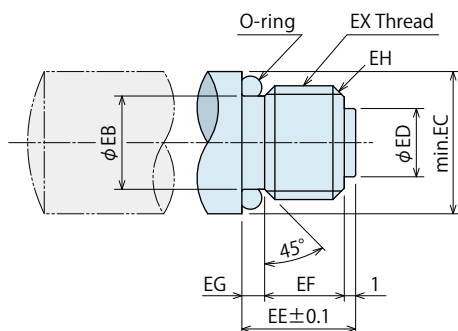

Model No. Indication

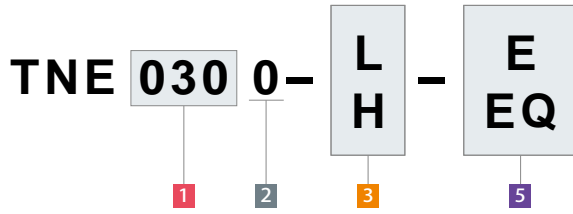

(Format Example : TNE0300-L-E,
TNE0450-H-EQ)

- 1 Body Size
- 2 Design No.
- 3 Plunger Spring Force
- 4 Plunger Action Confirmation (Blank)
- 5 Option : E / EQ
 - E : Spring Advance Model
 - EQ : Spring Advance Long Stroke Model

External Dimensions and Machining Dimensions for Mounting

Model No.	TNE0260-□-E	TNE0260-□-EQ	TNE0300-□-E	TNE0300-□-EQ	TNE0360-□-E	TNE0360-□-EQ	TNE0450-□-E	TNE0450-□-EQ
Plunger Stroke	6.5	13	8	16	10	20	12	24
A	66.5	77	73	85	86.5	102.5	100	119
B	24		27		32		41	
C	26		30		36		45	
D (Nominal×Pitch)	M26×1.5		M30×1.5		M36×1.5		M45×1.5	
E	47.1	51.1	52.1	56.1	59.6	65.6	69.2	76.2
F	6		6		7		7	
G	32.6	36.6	36.6	40.6	43.1	49.1	51.7	58.7
H	8.5		9.5		9.5		10.5	
J	24.2		28.2		34.2		43.2	
T	19.4	25.9	20.9	28.9	26.9	36.9	30.8	42.8
U	14		16		20		25	
V	6		6		8		8.5	
W	12		13		17		21	
X (Nominal×Pitch×Depth)	M10×1.5×11		M10×1.5×11		M12×1.75×13		M12×1.75×13	
BA	12.5		12.5		16.5		16.5	
BB	4		4		6		6	
BC	11		11		14		14	
CB	24.5		28.5		34.5		43.5	
CC	15 ~ 38	19 ~ 42	15 ~ 41	19 ~ 45	15 ~ 49	21 ~ 55	18 ~ 57	25 ~ 64
CD	CC-5		CC-5		CC-6		CC-6	
CE	max. 8		max. 10		max. 10		max. 12	
CF	p.c.d. 19		p.c.d. 22		p.c.d. 26		p.c.d. 30	
CG	max. 2.5		max. 3		max. 5		max. 6	
DA	AS568-013(90)		AS568-014(90)		AS568-015(90)		AS568-017(90)	AS568-018(90)
DB	AS568-020(90)		AS568-022(90)		AS568-026(90)		AS568-030(90)	
EY	SR50		SR50		SR80		SR80	
Tightening Torque for Main Body ※2	31.5 N·m		50 N·m		63 N·m		80 N·m	

Note : ※2. Please follow the tightening torque in the list when mounting Work Support.

Excessive tightening torque causes deformation of the product resulting in malfunction.

Insufficient tightening torque causes looseness of the product resulting in damage of the O-ring and oil leakage.

Contact Bolt Design Dimensions

※Reference for designing a contact bolt (attachment) by customer other than the included contact bolt.

Corresponding Model No.	TNE0260-□-E/EQ	TNE0300-□-E/EQ	TNE0360-□-E/EQ	TNE0450-□-E/EQ
EB	7.4	7.4	9.4	9.4
EC	12.5	12.5	16.5	16.5
ED	6	6	7.5	7.5
EE	10	10	12	12
EF	7.3	7.3	8.7	8.7
EG	1.7	1.7	2.3	2.3
EH	C1	C1	C1.2	C1.2
EX	M10	M10	M12	M12
O-ring	AS568-010(70)	AS568-010(70)	AS568-012(70)	AS568-012(70)
Tightening Torque for Contact Bolt	16N·m	16N·m	40N·m	40N·m
Reference	Material S45C			
	Quenching Hardness HRC50~55			
	Surface Finishing Alkaline Blackening			

Notes :

- It should be designed according to the weight of contact bolt and the plunger spring force.
- If using a contact bolt with different dimensions than those shown above, spring force will be different from the values on catalog, and the plunger spring will be damaged leading to malfunctions.

External Dimensions

TNE-□M : Hydraulic Advance Model

This drawing shows the released state of TNE-□M (before the plunger is lifted). Refer to Hydraulic Advance Model (Standard) (P.11, P.12) for unlisted dimensions.

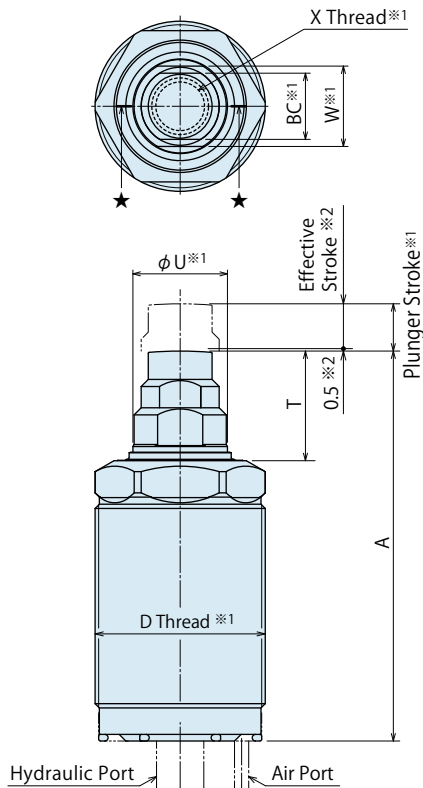

TNE-□M-E : Spring Advance Model

This drawing shows the released state of TNE-□M-E (when the plunger is lifted). Refer to Spring Advance Model (P.15, P.16) for unlisted dimensions.

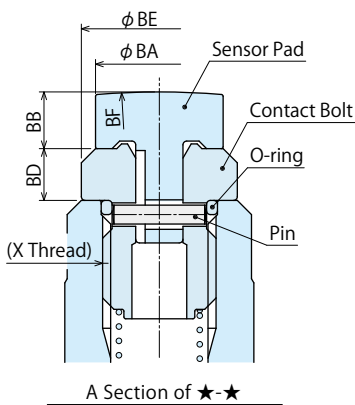
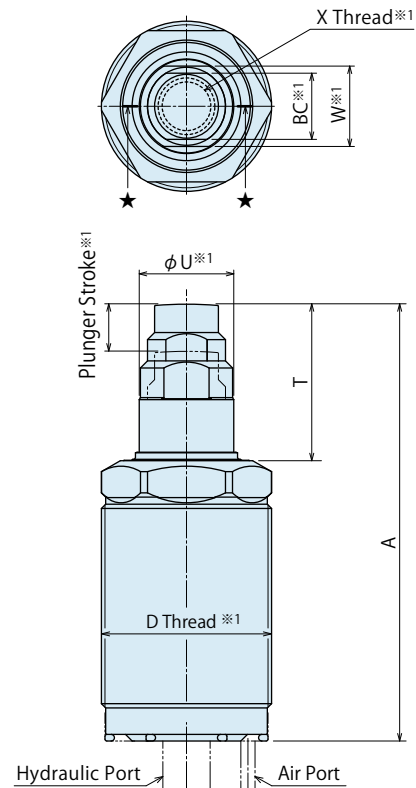

Notes :

- ※ 1. Dimensions with ※1 are the same as TNE Standard model and TNE-E model.
 - ※ 2. When the work support touches a workpiece within short stroke range, 0.5mm from the plunger retract-end, a force which is larger than the workpiece contact force (Refer to P.19 workpiece contact force formula when using air catch sensor) will be applied to the workpiece.
1. Even if the contact bolt for TNE Standard model, TNE-E model is exchanged with air sensing option, it does not work as air sensing option. An internal part must be changed with air sensing corresponding product.
 2. Please contact us for the dimensions of Long Stroke model.
 3. Please refer to P.19, P.20 for Air Sensing Chart.

Sensor Pad Design Dimension

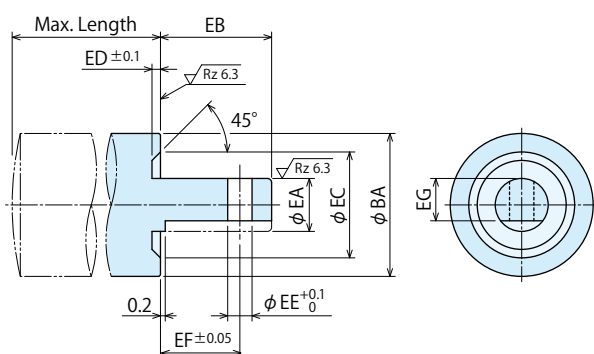

※ When changing the sensor pad, please design it according to the sensor pad design dimensions. (Please contact us when changing the contact bolt.)

Contact Bolt Adapter Design Dimensions

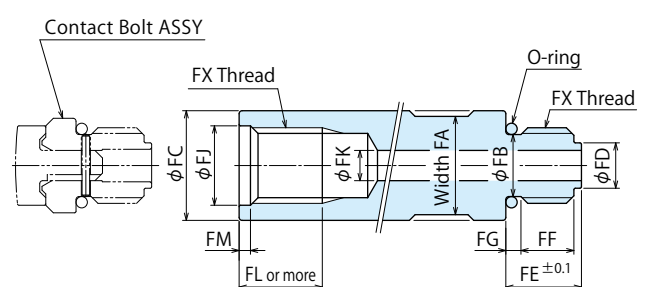

※ When a longer contact bolt is required, design it according to the contact bolt adapter design dimensions.

Model No. Indication

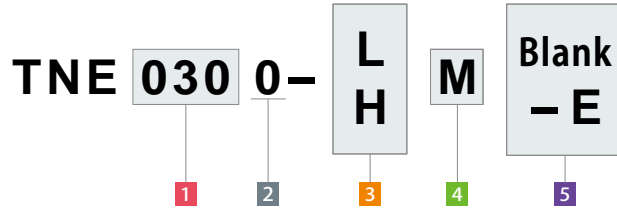

※ Contact us for TNE-M-Q、TNE-M-EQ.

(Format Example : TNE0300-HM-E,
TNE0450-LM)

- 1 Body Size
- 2 Design No.
- 3 Plunger Spring Force
- 4 Plunger Action Confirmation : M
- 5 Option : Blank / E
Blank : Hydraulic Advance Model
E : Spring Advance Model

External Dimensions and Machining Dimensions for Mounting

Model No.	TNE0260-□M TNE0260-□M-E	TNE0300-□M TNE0300-□M-E	TNE0360-□M TNE0360-□M-E	TNE0450-□M TNE0450-□M-E
Plunger Stroke ※1	6.5	8	10	12
Effective Stroke 5 Blank	6.0	7.5	9.5	11.5
A 5 Blank:Hydraulic Advance	64	69	82.5	94
5 E:Spring Advance	70.5	77	92.5	106
D (Nominal×Pitch) ※1	M26×1.5	M30×1.5	M36×1.5	M45×1.5
T 5 Blank:Hydraulic Advance	16.9	16.9	22.9	24.8
5 E:Spring Advance	23.4	24.9	32.9	36.8
U※1	14	16	20	25
W※1	12	13	17	21
X (Nominal×Pitch×Depth)※1	M10×1.5×11	M10×1.5×11	M12×1.75×13	M12×1.75×13
BA	10.5	10.5	13.5	13.5
BB	4	4	6	6
BC※1	11	11	14	14
BD	4	4	6	6
BE	12.5	12.5	16.5	16.5
BF	SR50	SR50	SR80	SR80
Pin (Diameter × Length)	φ1×7.8	φ1×7.8	φ2×9.8	φ2×9.8
O-ring	S8 (made by NOK)	S8 (made by NOK)	S10 (made by NOK)	S10 (made by NOK)

Note : ※ 1. The dimensions with ※1 are the same as TNE Standard model and TNE-E model.

Sensor Pad Design Dimension List

Corresponding Model No.	TNE0260-□M TNE0260-□M-E	TNE0300-□M TNE0300-□M-E	TNE0360-□M TNE0360-□M-E	TNE0450-□M TNE0450-□M-E
EA	4g7 ^{-0.004} / _{-0.016}	4g7 ^{-0.004} / _{-0.016}	5g7 ^{-0.004} / _{-0.016}	5g7 ^{-0.004} / _{-0.016}
EB	7.5	7.5	10.5	10.5
EC	8.5	8.5	10	10
ED	0.8	0.8	0.8	0.8
EE	1.2	1.2	2.3	2.3
EF	5.3	5.3	7.5	7.5
EG	3.2	3.2	3.9	3.9
Max. Length ※3	max. 8	max. 8	max. 12	max. 12

Note : ※3. Sensor response may decrease if the pad is longer than maximum length.

Contact Bolt Design Dimensions

Corresponding Model No.	TNE0260-□M / □M-E TNE0300-□M / □M-E	TNE0360-□M / □M-E TNE0450-□M / □M-E
FA	13	17
FB	8.2	10
FC	14.5	19.5
FD	6	7.5
FE	10	12
FF	7	8
FG	2	3
FJ	10.5	12.3
FK	4	5
FL	11	13
FM	1.5	1.5
FX	M10	M12
O-ring	S8 (made by NOK)	S10 (made by NOK)
Contact Bolt ASSY	XLC-M10SP	XLC-M12SP
Reference : Material	SCM435 Quenched and Tempered Material	
Reference : Surface Finishing	Nitriding	

Workpiece Contact Force Curve (Reference)

This graph shows the workpiece contact force (reference value) when a work support with Plunger Spring Force H : High Spring contacts a workpiece in the middle of plunger stroke.
※ Refer to P.19 for the calculation formula of workpiece contact force.

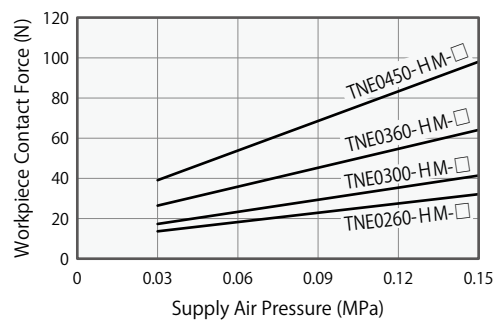

● Air Sensing Option (Plunger Action Confirmation···M : Air Sensing Option)

Plunger action is detected by the circuit at the air port like the drawing below. This is done by detecting the differential pressure between P1 and P2 with air sensor.

Applicable Model

TNE 030 0 -

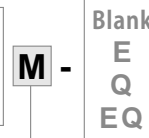

4 Plunger Action Confirmation : M

- Workpieces even with rough, casting or forged surface can be accurately detected since the structure does not detect the workpiece surface directly.
- Detected with higher accuracy compared to a switch detection with a dog, etc.
- Designed to prevent coolant from entering into the sensing area.

Structure Drawing

Recommended Air Pressure : 0.05 ~ 0.15MPa

Recommended Air Sensor

Manufacturer	SMC	CKD
Name	Air Catch Sensor	Gap Switch
Model No.	ISA3-G	GPS3-E

- The Number of Work Supports Connected per Air Sensor : 1 ~ 4

TNE Released State (Air Sensor OFF)

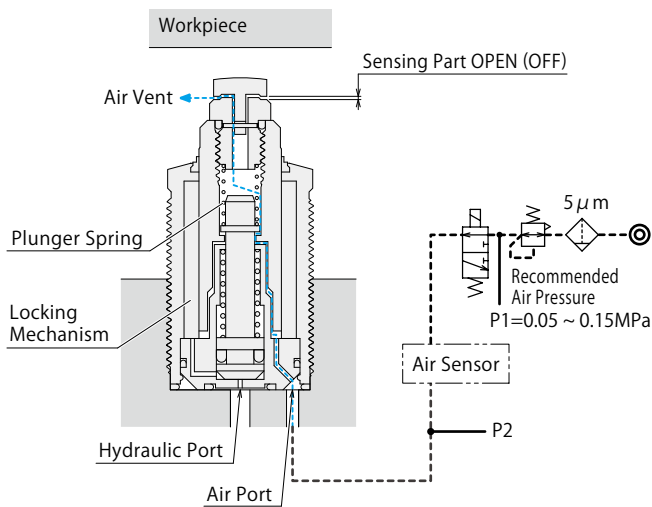

TNE Plunger Extends • Contacts Workpiece (Air Sensor ON)

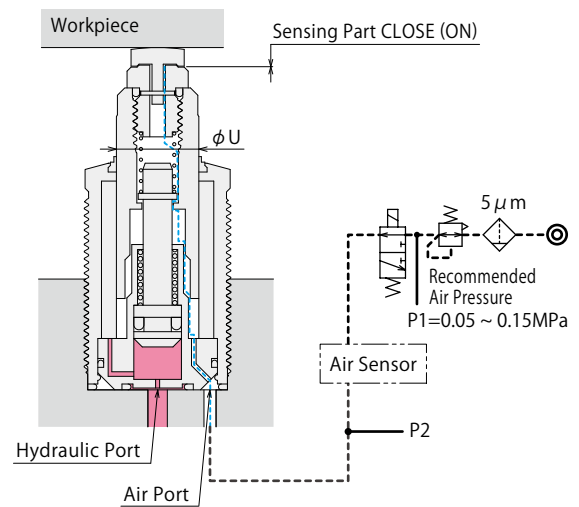

Workpiece Contact Force Formula when using Air Sensor ※1

$$\text{Workpiece Contact Force (N)} = \text{Plunger Spring Force (N)} + \text{Supply Air Pressure (MPa)} \times U^2 \text{ (mm)} \times \pi / 4$$

Model No.		TNE0260-□M-□	TNE0300-□M-□	TNE0360-□M-□	TNE0450-□M-□
U	mm	14	16	20	25
Plunger ※2	L : Low Spring Force	5.3 ~ 7.8	6.6 ~ 9.7	9.3 ~ 14.6	11.8 ~ 18.6
	H : High Spring Force	7.0 ~ 11.0	9.0 ~ 13.5	12.1 ~ 21.9	15.4 ~ 33.4
Spring Force	Q : Hydraulic Advance Long Stroke Model	7.4 ~ 12.9	9.1 ~ 16.3	12.1 ~ 26.7	15.4 ~ 27.8
	N EQ : Spring Advance Long Stroke Model				

Notes :

- ※1. Please prepare a stopper if necessary when using light and/or thin workpiece. Otherwise it might be pushed up by work support.
- ※2. The plunger spring force indicates the spring design value. It may vary depending on sliding resistance of the plunger and characteristic of the spring, etc. Please read it as a reference value of workpiece contact force.

Air Sensing Chart

Connect one work support with one air sensor
Supply Pressure of Air Sensor P1=0.1MPa

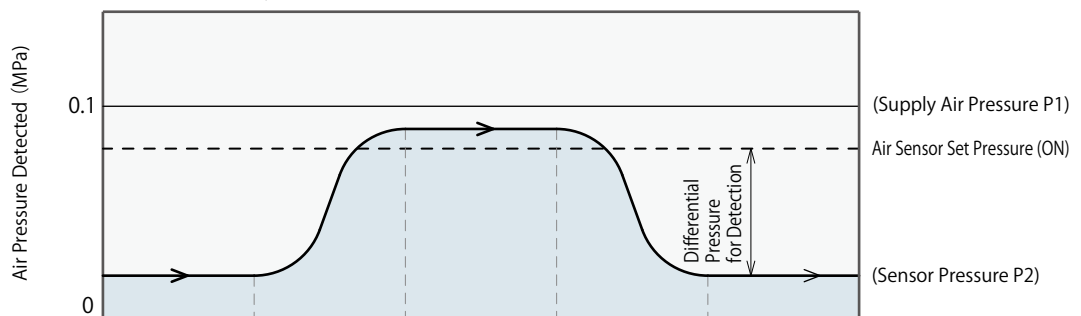

Air Sensor		OFF	OFF→ON	ON	ON→OFF	OFF
Hydraulic Advance Model	Hydraulic Valve	Hydraulic Pressure OFF	Hydraulic Pressure ON	Hydraulic Pressure ON	Hydraulic Pressure OFF	Hydraulic Pressure OFF
	Work Support Action	Released State	Ascending Completed Locking State	Locking Completed	Releasing State Descending State	Releasing Completed
Spring Advance Model	Hydraulic Valve	Hydraulic Pressure OFF	Hydraulic Pressure OFF	Hydraulic Pressure ON	Hydraulic Pressure OFF	Hydraulic Pressure OFF
	Work Support Action	Released State	Loading Workpiece	Locking Completed	Unloading Workpiece	Releasing Completed

Note: 1. Depending on the usage condition, the detection differential pressure may be decreased by repeated action. Please contact us for overhaul when the detection differential pressure is decreased.

Connect four work supports with one air sensor
Supply Pressure of Air Sensor P1=0.1MPa

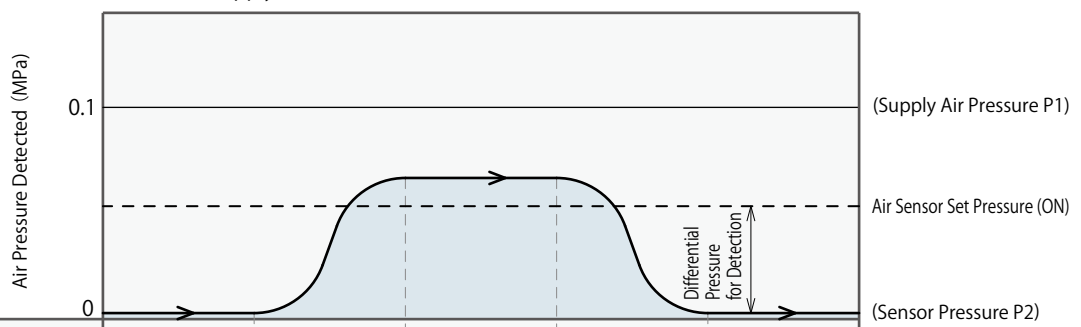

Air Sensor		OFF	OFF→ON	ON	ON→OFF	OFF
Hydraulic Advance Model	Hydraulic Valve	Hydraulic Pressure OFF	Hydraulic Pressure ON	Hydraulic Pressure ON	Hydraulic Pressure OFF	Hydraulic Pressure OFF
	Work Support Action	Released State	Ascending Completed Locking State	Locking Completed	Releasing State Descending State	Releasing Completed
Spring Advance Model	Hydraulic Valve	Hydraulic Pressure OFF	Hydraulic Pressure OFF	Hydraulic Pressure ON	Hydraulic Pressure OFF	Hydraulic Pressure OFF
	Work Support Action	Released State	Loading Workpiece	Locking Completed	Unloading Workpiece	Releasing Completed

Notes: 1. Depending on the usage condition, the detection differential pressure may be decreased by repeated action. Please contact us for overhaul when the detection differential pressure is decreased.
2. In order to carry out stabilized detection, the number of work supports connected per air sensor should be four or less.

Notes

- This specification is designed for confirming the plunger action of the work support. If it is used for confirming the close contact with the workpiece, other clamping (force) is necessary.
- If the plunger goes up too fast, it may bounce back and locks itself. Resulting in a gap with the workpiece and possible damage to the internal parts due to the impact force. Set the plunger action time at 0.5-1.0 sec. to adjust the air supply with the flow control valve with check valve (meter-in), and make sure that there is no clearance with the workpiece for operation.
- The sensor air port needs to have air supply at all the times. If it is used when the air supply is shut off, the coolant or cutting chips may contaminate the sensing area, leading to malfunctioning of the work support and breakage of the air sensor.
- Even if the contact bolt for TNE standard model/TNE-E model is exchanged with air sensing option, it does not work as air sensing option. Internal part (plunger) must be changed with air sensor corresponding product.
- In case plunger descending is slower due to air pressure or workpiece unloading condition, stop air supply temporarily during descending action.

Air Purge Function

TNE is equipped with the special dust seal that features low friction and high sealing capabilities. However, when using TNE in worse condition, air purge function is available by providing the circuit to the air vent port like the drawing below.

Structure Drawing

TNE Plunger Descending and at Releasing State (Air Supply OFF) ※1

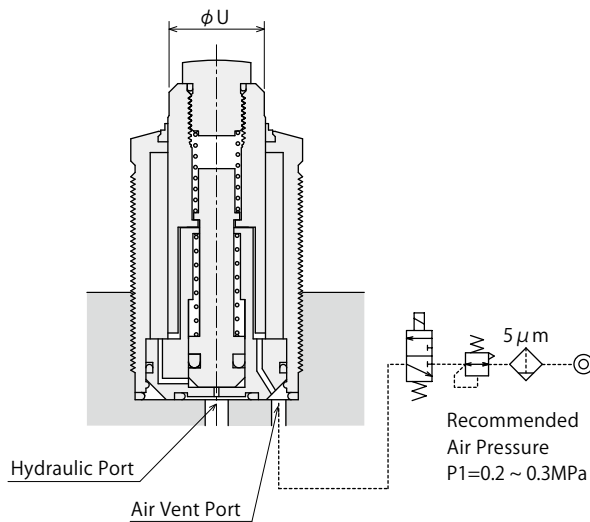

TNE Plunger Ascending and at Locking State (Air Supply ON) ※1

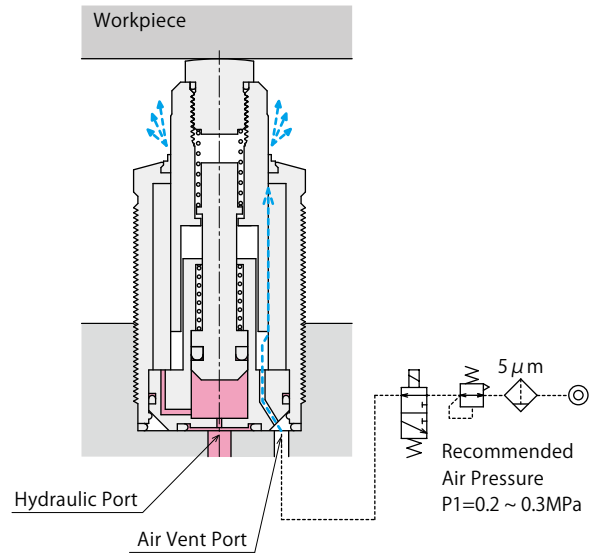

Workpiece Contact Force Formula when Using Air Purge Function ※2

$$\text{Workpiece Contact Force (N)} = \text{Plunger Spring Force (N)} + \text{Supply Air Pressure (MPa)} \times U^2 \text{ (mm)} \times \pi / 4$$

Model No.		TNE0260-□-□	TNE0300-□-□	TNE0360-□-□	TNE0450-□-□
		TNE0260-Q	TNE0300-Q	TNE0360-Q	TNE0450-Q
		TNE0260-EQ	TNE0300-EQ	TNE0360-EQ	TNE0450-EQ
U	mm	14	16	20	25
Plunger ※3 Spring Force	L : Low Spring Force	5.3 ~ 7.8	6.6 ~ 9.7	9.3 ~ 14.6	11.8 ~ 18.6
	H : High Spring Force	7.0 ~ 11.0	9.0 ~ 13.5	12.1 ~ 21.9	15.4 ~ 33.4
	Q : Hydraulic Advance Long Stroke Model				
N	EQ : Spring Advance Long Stroke Model	7.4 ~ 12.9	9.1 ~ 16.3	12.1 ~ 26.7	15.4 ~ 27.8

Notes :

- ※2. Please prepare a stopper if necessary when using light and/or thin workpiece. Otherwise it might be pushed up by work support.
- ※3. The plunger spring force indicates the spring design value. It may vary depending on sliding resistance of the plunger and characteristic of the spring , etc. Please read it as a reference value of workpiece contact force.

Notes

- ※1. When the plunger is descending, shut off the air supply. The plunger does not go back when air is supplied.
 1. If the plunger ascends too fast, it may bounce back and locks itself resulting in a gap with the workpiece, and possible damage to the internal parts due to the impact. Set the plunger action time at 0.5-1.0 sec. to adjust the air supply with the flow control valve with check valve (meter-in), and make sure that there is no clearance with the workpiece for operation.
 2. Air cannot be vented as the air supply pressure is too low because the cracking pressure at the dust seal lip is about 0.1MPa.

● Plunger Spring Design Dimension

※Reference for designing a plunger spring by customer other than the included plunger spring.

※This drawing shows the released state.

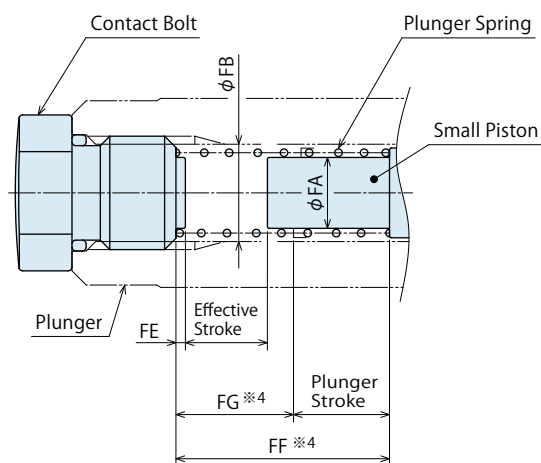

(mm)

Corresponding Model No.	TNE0260-□	TNE0300-□	TNE0360-□	TNE0450-□
	TNE0260-□M	TNE0300-□M	TNE0360-□M	TNE0450-□M
	TNE0260-□-E	TNE0300-□-E	TNE0360-□-E	TNE0450-□-E
	TNE0260-□M-E	TNE0300-□M-E	TNE0360-□M-E	TNE0450-□M-E
FA	6	6	7.5	7.5
FB	8.5	8.5	10.3	10.3
FE	1	1	1	1
FF*4	16.1	17.6	20.6	22.6
FG*4	9.6	9.6	10.6	10.6
Plunger Stroke	6.5	8	10	12
Effective Stroke	6.0	7.5	9.5	11.5

(mm)

Corresponding Model No.	TNE0260-Q	TNE0300-Q	TNE0360-Q	TNE0450-Q
	TNE0260-EQ	TNE0300-EQ	TNE0360-EQ	TNE0450-EQ
FA	6	6	7.5	7.5
FB	8.5	8.5	10.3	10.3
FE	1	1	1	1
FF*4	25.6	28.6	32.8	40.5
FG*4	12.6	12.6	12.8	16.5
Plunger Stroke	13	16	20	24
Effective Stroke	12.5	15.5	19.5	23.5

Note :

※ 4. When designing a spring, make sure that the spring set length is below FF dimension and the spring contact length is below FG dimension.

Cautions

● Notes for Design

1) Check Specifications

- Please use each product according to the specifications.
- When using a work support opposite to the clamp, set the support force at more than 1.5 times the clamping force.

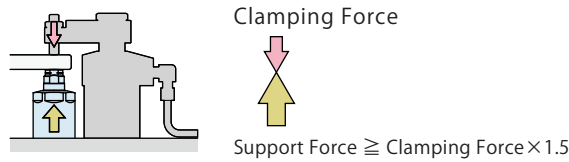

2) Notes for Circuit Design

- Please read "Notes on Hydraulic Cylinder Speed Control Unit" for proper hydraulic circuit design. Improper circuit design may lead to malfunctions and damages. (Refer to P.25)

3) Install a temporary stopper for a workpiece if necessary.

- When multiple work supports are used for a light workpiece, the plunger spring force may be higher than the workpiece weight, causing the workpiece to be pushed up.

4) An attachment is required for the plunger.

- Make sure that an attachment is installed to the plunger. Otherwise, the plunger does not advance since the plunger spring is free to move.
- Make sure to set the O-ring to the attachment. Otherwise, cutting fluid or other contaminants will get in easily, causing malfunction.

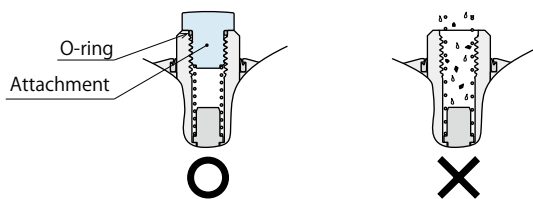

5) Protect the plunger surface when using on a welding fixture.

- If spatter attaches to the sliding surface it may lead to a sliding failure and an insufficient support function.

6) Do not expose the plunger directly to high-pressure coolant.

- It will cause intrusion of the coolant and damage to the internal components.

7) For Using on a Lathe, High-Speed Tilting Table, and etc.

- When using in a cycle where the centrifugal force is acting, the work support should be in a locked state. Please contact us for further information.

8) Adjust the plunger operation time with flow rate.

- A rough guideline for the full stroke is between 0.5 and 1 second.
- As with single-action cylinders, use a flow regulating valve with a check valve (meter-in) in consideration of the decreasing speed at release.
- If the action speed is too fast, the plunger may bounce back and locks itself resulting in a gap with the workpiece.
- Use a flow regulating valve with check valve that has 0.1 MPa or less of cracking pressure. If the cracking pressure is too high the plunger will not move at the time of release.

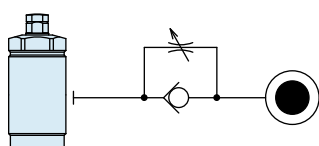

9) Appropriate Measures for Air Vent Port

- The work support, although only slightly, breathes like a single-acting cylinder. Consider the environment and avoid cutting fluid, coolant or any contaminants.
- If using it without air vent port, it will not function properly. Make sure it breathes without the influence of cutting chips or coolant.

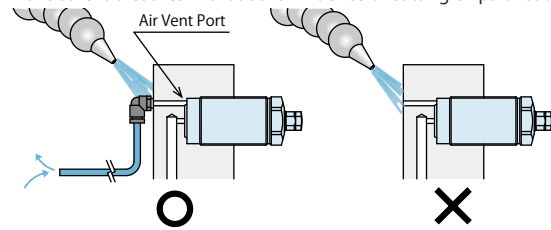

10) Make sure that offset load and component of force do not affect the product.

- If using the product as illustrated below, the displacement against load will be increased. Also large load will damage the internal parts.

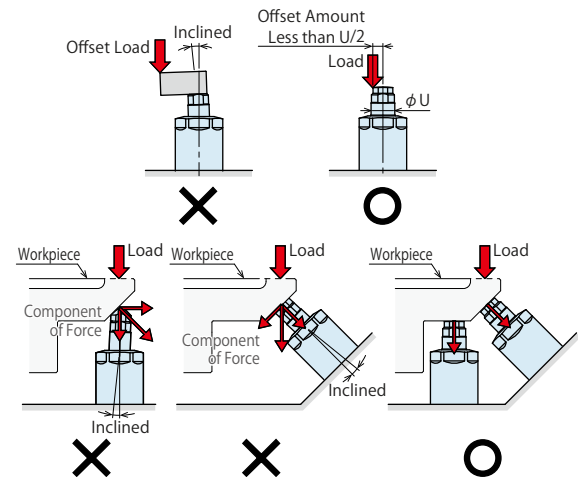

11) The Weight of an Attachment

- When designing an attachment, make sure the attachment weight is 30% or less of the plunger spring force.

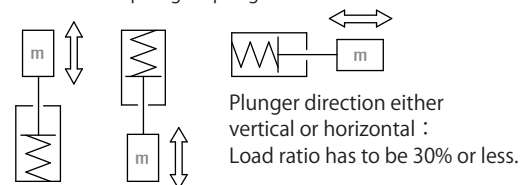

- Ex.) In case of TNE0300-L with the plunger spring force 6.6–9.7N. The maximum weight of the contact bolt = $6.6 \times 0.3 / 9.807 = 0.2\text{kg}$. Since it may vary depending on sliding resistance of the plunger and characteristic of the spring, it is recommended to design the contact bolt as light as possible.

- The dimensions of the mounting thread area need to be processed according to the design dimensions for contact bolts as shown on the respective product pages.

The knockout function is used to release fixation of plunger spring and adherence after machine stop for a long time. Using an attachment with different thread part dimension leads to inappropriate spring force and effective stroke, causing damage and malfunctions.

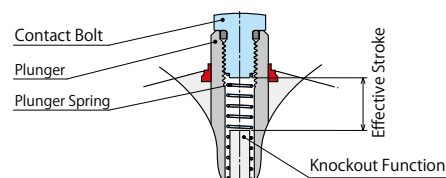

Notes for Design

1) Notes on Mounting Method of TNE (Threaded Model)

- When mounting TNE, make sure the base is horizontal to the bearing surface, and the load is received at the base. With the following installations, the load cannot be received at the base, leading to increase of displacement amount and damage on the product.

【Examples of Improper Use】

- ① Work support is lifted up by tightening the partition nut, and the load cannot be received on the bearing surface.

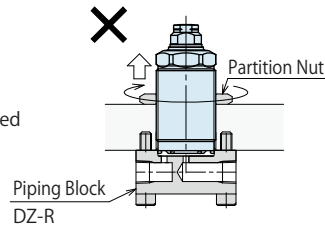

- ② Bearing surface contact part is not horizontal, a clearance occurs and it cannot receive the load. Moreover, there is a possibility of damaging equipment by tightening bolts.

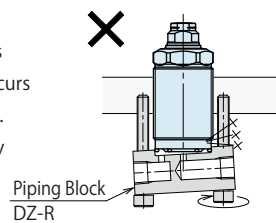

- ③ Since the piping block to receive the load is floated, it cannot receive the load.

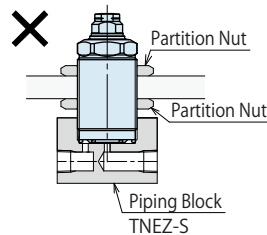

【Example of Proper Use】

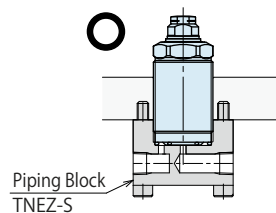

Installation Notes

1) Check the Usable Fluid

- Please use the appropriate fluid by referring to the Hydraulic Fluid List (P.25).

2) Preparation for Piping

- The pipeline, piping connector and fixture circuits should be cleaned by thorough flushing.
- The dust and cutting chips in the circuit may lead to fluid leakage and malfunction.
- There is no filter provided with Kosmek's product except for a part of valves which prevents foreign materials and contaminants from getting into the circuit.

3) Applying Sealing Tape

- Wrap with tape 1 to 2 times following the screwing direction.
- Pieces of the sealing tape can lead to air leakage and malfunction.
- Please implement piping construction in a clear environment to prevent anything getting in products.

4) Installation of the Product

- When mounting TNE (Threaded Model), be careful not to damage the O-ring for sealing the base. Tighten them with the torque shown in the table below.

Model No.	Thread Size	Tightening Torque (N·m)
TNE0260	M26×1.5	31.5
TNE0300	M30×1.5	50
TNE0360	M36×1.5	63
TNE0450	M45×1.5	80

- Apply an adequate amount of grease to the O-ring.
- If it is mounted under dry state, the O-ring may have twisting or be defective.
- If it is tightened with higher torque, it may lead to malfunction.

5) Replacement of Attachment

- Release supplying pressure to the work support before replacing the attachment.
- Do not lose the plunger spring when the attachment (contact bolt) is removed.
- When mounting the attachment, stop the plunger with a spanner at edge and tighten it with torque as shown in the table below.

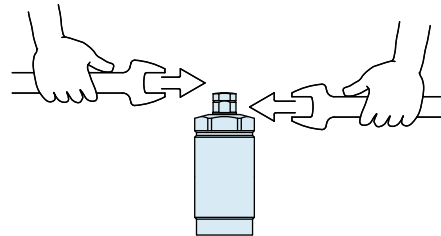

Model No.	Head Thread Size	Tightening Torque (N·m)
TNE0260	M10×1.5	16
TNE0300	M10×1.5	16
TNE0360	M12×1.75	40
TNE0450	M12×1.75	40

6) Air Bleeding of the Hydraulic Circuit

- If the hydraulic circuit has excessive air, the action time may become very long. If air enters the circuit after connecting the hydraulic port or under the condition of no air in the oil tank, please perform the following steps.

- Reduce hydraulic pressure to less than 2MPa.
- Loosen the cap nut of pipe fitting closest to the clamp by one full turn.
- Shake the pipeline to loosen the outlet of pipe fitting. Hydraulic fluid mixed with air comes out.

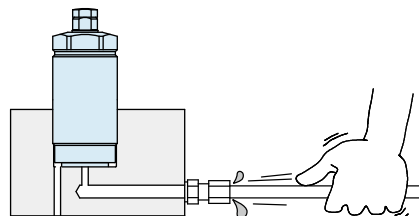

- Tighten the cap nut after bleeding.
- It is more effective to release air at the highest point inside the circuit or at the end of the circuit.

7) Checking Looseness and Retightening

- At the beginning of the machine installation, the bolt and nut maybe tightened lightly. Check the looseness and re-tighten as required.

Cautions

● Hydraulic Fluid List

Maker	ISO Viscosity Grade ISO-VG-32	
	Anti-Wear Hydraulic Oil	Multi-Purpose Hydraulic Oil
Showa Shell Sekiyu	Tellus S2 M 32	Morlina S2 B 32
Idemitsu Kosan	Daphne Hydraulic Fluid 32	Daphne Super Multi Oil 32
JX Nippon Oil & Energy	Super Hyrando 32	Super Mulpus DX 32
Cosmo Oil	Cosmo Hydro AW32	Cosmo New Mighty Super 32
ExxonMobil	Mobil DTE 24	Mobil DTE 24 Light
Matsumura Oil	Hydol AW-32	
Castrol	Hyspin AWS 32	

Note : Please contact manufacturers when customers require products in the list above.

● Notes on Hydraulic Cylinder Speed Control Unit



Please pay attention to the cautions below. Design the hydraulic circuit for controlling the action speed of hydraulic cylinder. Improper circuit design may lead to malfunctions and damages. Please review the circuit design in advance.

● Flow Control Circuit for Single Acting Cylinder

For spring return single acting cylinders, restricting flow during release can extremely slow down or disrupt release action. The preferred method is to control the flow during the lock action using a valve that has free-flow in the release direction. It is also preferred to provide a flow control valve at each actuator.

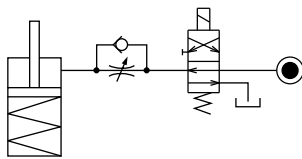

Accelerated clamping speed by excessive hydraulic flow to the cylinder may sustain damage. In this case add flow control to regulate flow. (Please add flow control to release flow if the lever weight is put on at the time of release action when using swing clamps.)

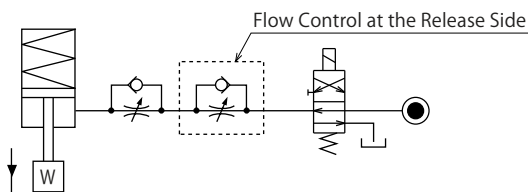

● Single acting components should not be used in the same flow control circuit as the double acting components. The release action of the single acting cylinders may become erratic or very slow.

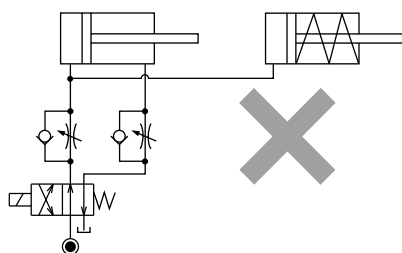

Refer to the following circuit when both the single acting cylinder and double acting cylinder are used together.

○ Separate the control circuit.

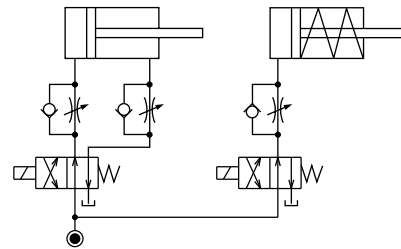

○ Reduce the influence of double acting cylinder control unit. However, due to the back pressure in tank line, single acting cylinder is activated after double acting cylinder works.

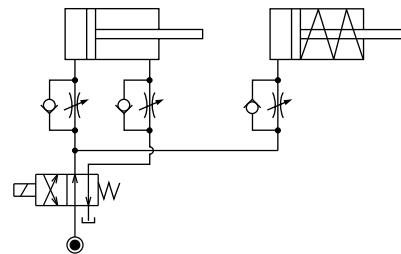

● Notes on Handling

- 1) It should be operated by qualified personnel.
 - Machines and devices with hydraulic and pneumatic products should be operated and maintained by qualified personnel.
- 2) Do not operate or remove the product unless the safety protocols are ensured.
 - ① Machines and devices can only be inspected or prepared when it is confirmed that the safety devices are in place.
 - ② Before the product is removed, make sure that the above-mentioned safety devices are in place. Shut off the pressure and power source, and make sure no pressure exists in the air and hydraulic circuits.
 - ③ After stopping the product, do not remove until the temperature drops.
 - ④ Make sure there is no trouble/issue in the bolts and respective parts before restarting a machine or device.
- 3) Do not touch the plunger while the work support is working. Otherwise, your hands may be injured due to clinching.



- 4) Do not disassemble or modify.
 - If the equipment is taken apart or modified, the warranty will be voided even within the warranty period.

● Warranty

- 1) Warranty Period
 - The product warranty period is 18 months from shipment from our factory or 12 months from initial use, whichever is earlier.
- 2) Warranty Scope
 - If the product is damaged or malfunctions during the warranty period due to faulty design, materials or workmanship, we will replace or repair the defective part at our expense. Defects or failures caused by the following are not covered.
 - ① If the stipulated maintenance and inspection are not carried out.
 - ② If the product is used while it is not suitable for use based on the operator's judgment, resulting in defect.
 - ③ If it is used or operated in an inappropriate way by the operator. (Including damage caused by the misconduct of the third party.)
 - ④ If the defect is caused by reasons other than our responsibility.
 - ⑤ If repair or modifications are carried out by anyone other than Kosmek, or without our approval and confirmation, it will void warranty.
 - ⑥ Other caused by natural disasters or calamities not attributable to our company.
 - ⑦ Parts or replacement expenses due to parts consumption and deterioration. (Such as rubber, plastic, seal material and some electric components.)

Damages excluding from direct result of a product defect shall be excluded from the warranty.

● Maintenance and Inspection

- 1) Removal of the Machine and Shut-off of Pressure Source
 - Before the machine is removed, make sure that safety devices and preventive devices are in place. Shut off the pressure and power source, and make sure no pressure exists in the air and hydraulic circuits.
 - Make sure there is no abnormality in the bolts and respective parts before restarting.
- 2) Regularly clean the area around the piston rod and plunger.
 - If it is used when the surface is contaminated with dirt, it may lead to packing seal damage, malfunctioning and fluid leakage.

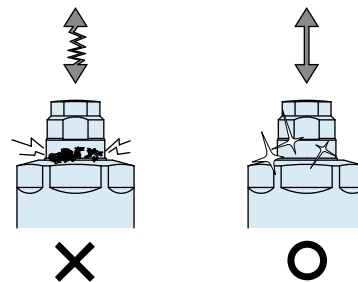

- 3) If disconnecting by couplers, air bleeding should be carried out on a regular basis to avoid air mixed in the circuit.
- 4) Regularly tighten piping joint, attachment, work support body and others to ensure proper use.
- 5) Make sure the hydraulic fluid has not deteriorated.
- 6) Make sure there is a smooth action without an irregular noise.
 - Especially when it is restarted after left unused for a long period, make sure it can be operated correctly.
- 7) The products should be stored in the cool and dark place without direct sunshine or moisture.
- 8) Please contact us for overhaul and repair.

Manifold Block

Model TNEZ-S

Model TNEZ-SQ



● Applicable Model/Application Examples

Model **TNEZ-S**

Manifold Block for TNE

Corresponding Model: TNE

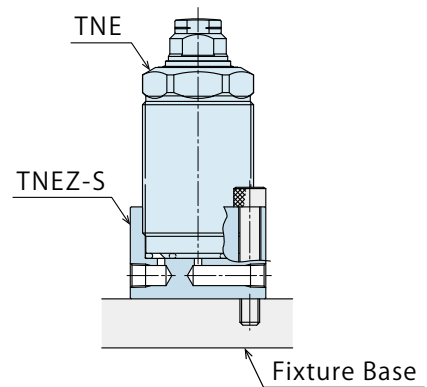

Model **TNEZ-SQ**

Manifold Block for TNE-Q

Corresponding Model: TNE-Q

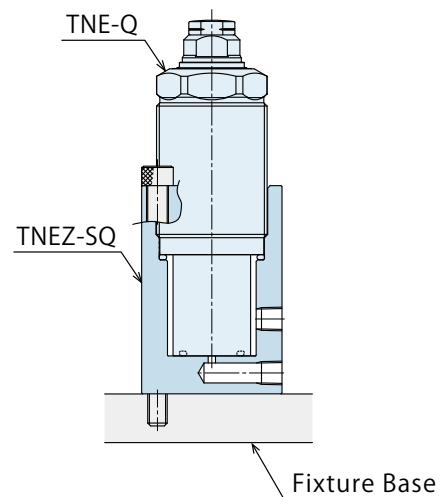

● **Manifold Block for TNE**

Model No. Indication

TNEZ 026 0 - S

Size (Refer to following table)

Design No. (Revision Number)

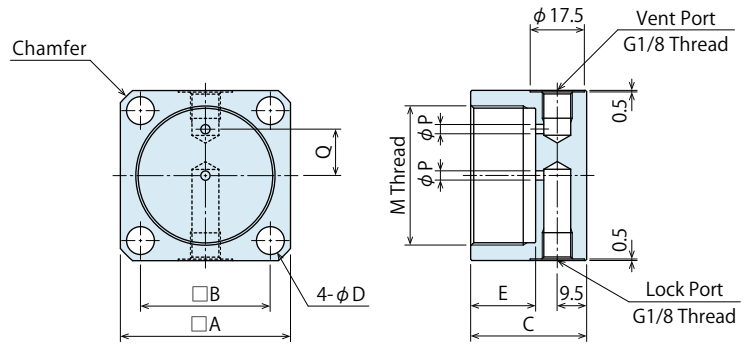

(mm)

Model No.	TNEZ0260-S	TNEZ0300-S	TNEZ0360-S	TNEZ0450-S
Corresponding Model No.	TNE0260 ^{※1}	TNE0300 ^{※1}	TNE0360 ^{※1}	TNE0450 ^{※1}
A	35	38	45	55
B	26	29	35	42
C	32.5	33.5	34.5	37.5
D	5.5	5.5	6.8	9
E	16	17	18	21
M (Nominal × Pitch)	M26×1.5	M30×1.5	M36×1.5	M45×1.5
P	2.5	3	3	3
Q	9.5	11	13	15
Chamfer	C3	C3	C3	C4
Weight	kg 0.20	0.23	0.34	0.52

Notes : 1. Material :S45C Surface Finishing :Alkaline Blackening
 2. Mounting bolts are not provided. Prepare mounting bolts according to the mounting height using the dimension C as a reference.
 ※1. It is not applicable for TNE-Q:Work Support Hydraulic Advance Long Stroke Option. (Please select from TNEZ-SQ.)

● **Manifold Block for TNE-Q**

Model No. Indication

TNEZ 026 0 - SQ

Size (Refer to following table)

Design No. (Revision Number)

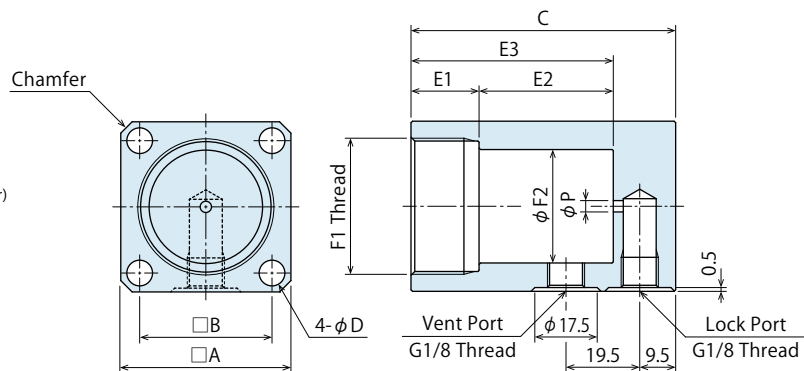

(mm)

Model No.	TNEZ0260-SQ	TNEZ0300-SQ	TNEZ0360-SQ	TNEZ0450-SQ
Corresponding Model No.	TNE0260-Q ^{※2}	TNE0300-Q ^{※2}	TNE0360-Q ^{※2}	TNE0450-Q ^{※2}
A	35	38	45	55
B	26	29	35	42
C	56	63.5	70	86.5
D	5.5	5.5	6.8	9
E1	20	21	18	21
E2	19.5	26	35.5	49
E3	39.5	47	53.5	70
F1 (Nominal × Pitch)	M26×1.5	M30×1.5	M36×1.5	M45×1.5
F2	20	24	30	39
P	2.5	3	3	3
Chamfer	C3	C3	C3	C4
Weight	kg 0.33	0.43	0.68	1.16

Notes : 1. Material :S45C Surface Finishing :Alkaline Blackening
 2. Mounting bolts are not provided. Prepare mounting bolts according to the mounting height using the dimension C as a reference.
 ※2. It is not applicable for TNE-EQ:Work Support Spring Advance Long Stroke Option. (Please select from TNEZ-S.)

● MEMO

 **MEMO**

Work Support

Accessory



KOSMEK LTD.

▶ <https://www.kosmek.com/>

HEAD OFFICE 1-5, 2-chome, Murotani, Nishi-ku, Kobe-city, Hyogo, Japan 651-2241
TEL.+81-78-991-5162 FAX.+81-78-991-8787

United States of America SUBSIDIARY	KOSMEK (USA) LTD. 650 Springer Drive, Lombard, IL 60148 USA TEL. +1-630-620-7650 FAX. +1-630-620-9015
MEXICO BRANCH OFFICE	KOSMEK USA MEXICO BRANCH OFFICE Av. Loma Pinal de Amoles 320-piso PH oficina 504 interior 13, Vista Dorada, 76060 Santiago de Querétaro, Qro. Mexico TEL. +52-442-851-1377
EUROPE SUBSIDIARY	KOSMEK EUROPE GmbH Schleppeplatz 2 9020 Klagenfurt am Wörthersee Austria TEL. +43-463-287587 FAX. +43-463-287587-20
CHINA SUBSIDIARY	KOSMEK (CHINA) LTD. Room601, RIVERSIDE PYRAMID No.55, Lane21, Pusan Rd, Pudong Shanghai 200125, China TEL. +86-21-54253000
INDIA BRANCH	KOSMEK LTD. - INDIA 4A/Old No:649, Ground Floor, 4th D cross, MM Layout, Kavalbyrasandra, RT Nagar, Bangalore -560032 India TEL.+91-9880561695
THAILAND REPRESENTATIVE OFFICE	KOSMEK Thailand Representation Office No.139, Blue Chips Building, 4th Floor, Room No.422, Soi Sukhumvit 63 (Thong Lor 10), Sukhumvit Road, Khlong Tan Nuea, Wattana, Bangkok 10110, Thailand TEL. +66(0)2-059-2010

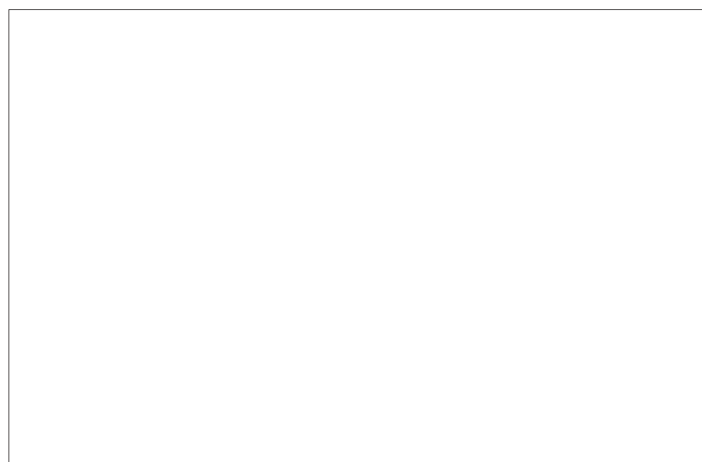

- For Further Information on Unlisted Specifications and Sizes, Please call us.
- Specifications in this Leaflet are Subject to Change without Notice.



JQA-QMA10823
KOSMEK HEAD OFFICE