

New

For Diecast Systems

Manual Ejector Coupler

Connect ejector rod and ejector plate in mere seconds

Simple Setup / Setup Time Reduction / Improve Productivity

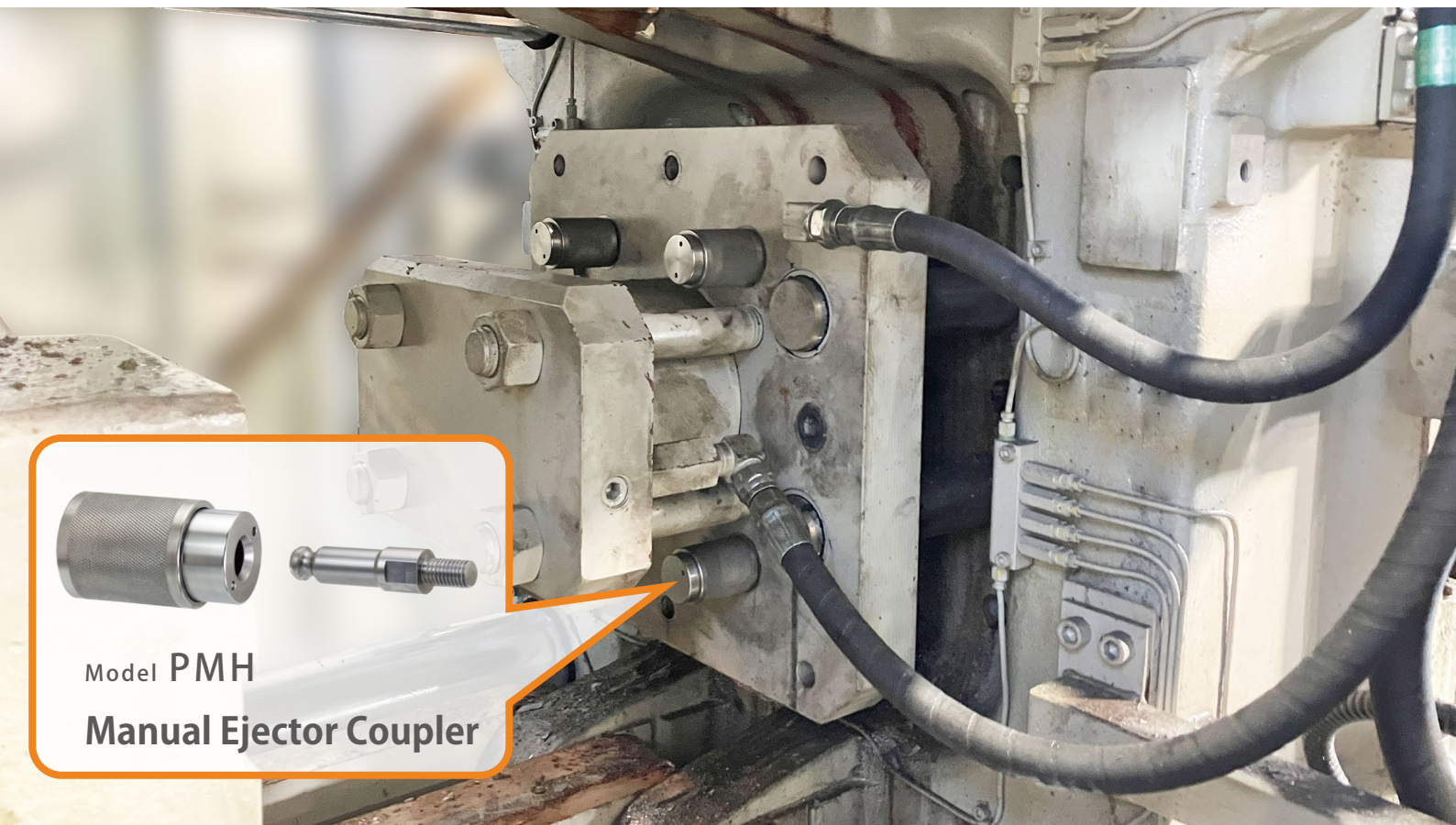

Model PMH

Manual Ejector Coupler

For Diecast Systems

Manual Ejector Coupler

Model **PMH**



Quick Change Manual Ejector Coupler

Connect ejector rod and ejector plate in mere seconds.

No tools required to connect
Ejector Rod and Ejector Plate!

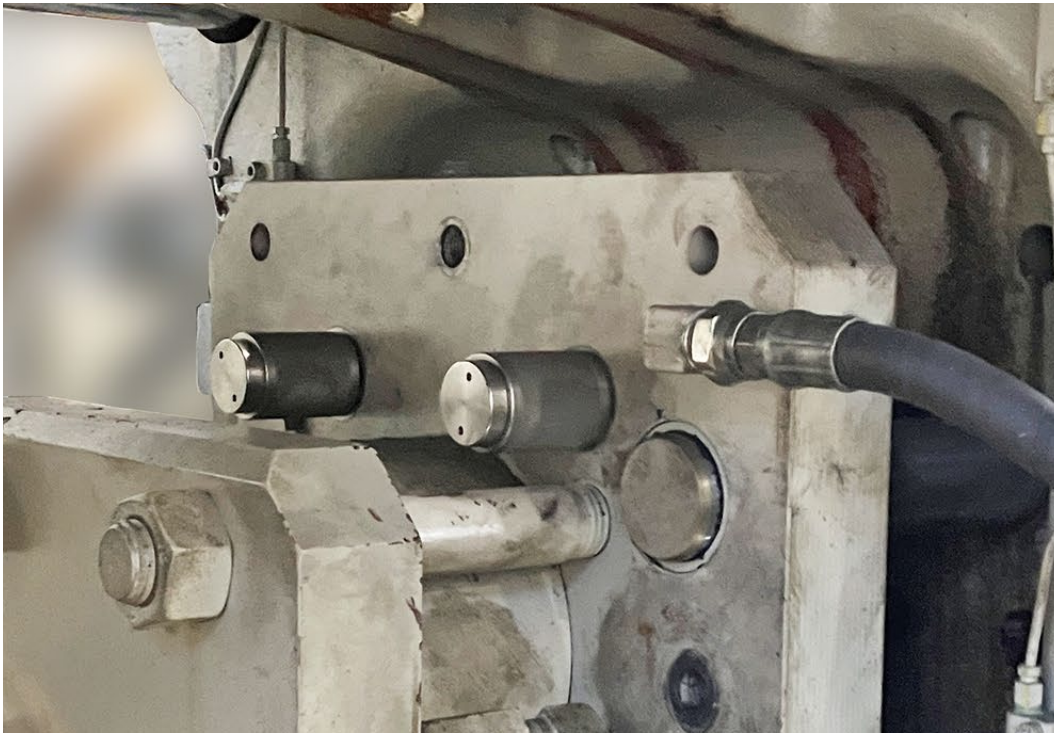

Complete dangerous work behind
the movable platen in mere seconds.

Current Method

In general, an ejector rod and an ejector plate are connected by double nut, but this takes a lot of time to tighten and untighten.

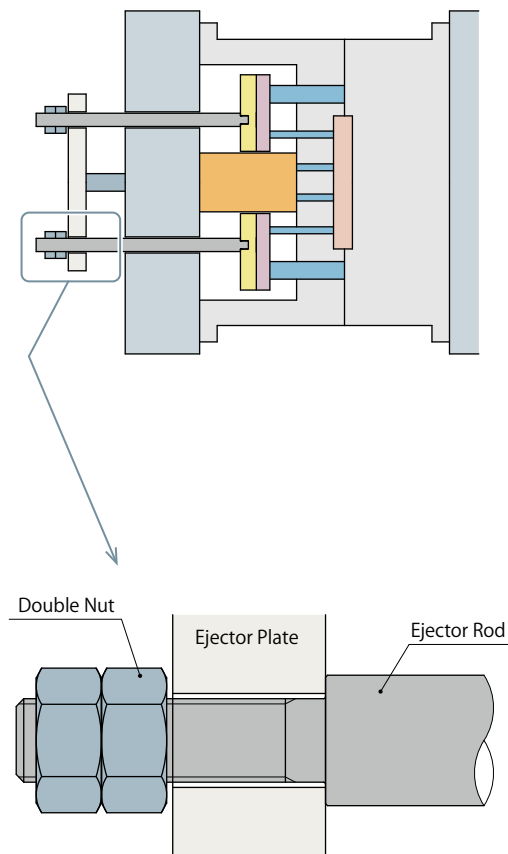

Manual Ejector Coupler

Manual Ejector Coupler enables one-touch connection of the ejector rod and ejector plate.

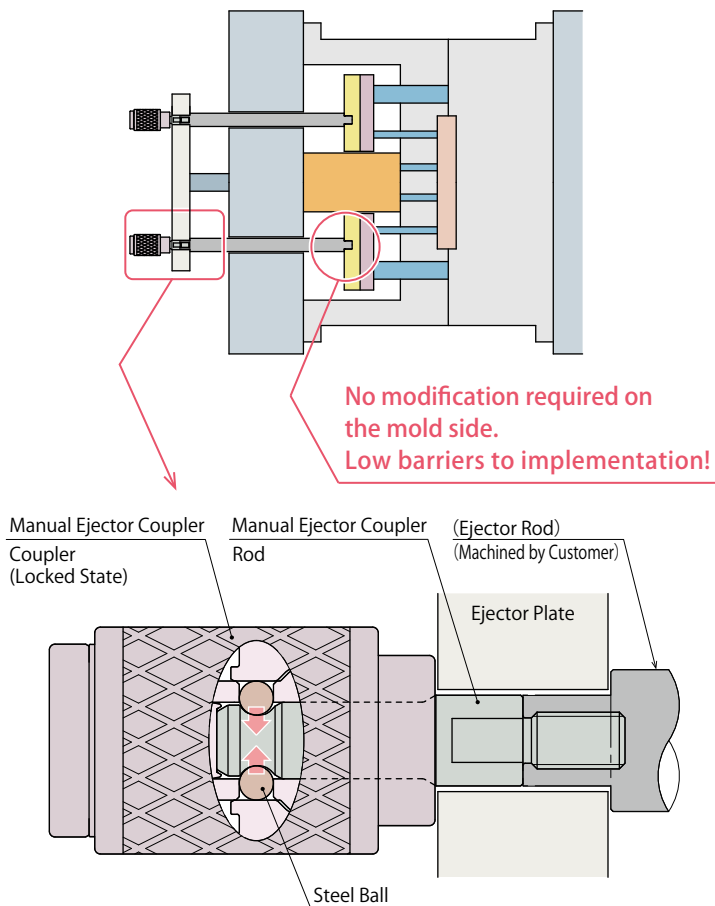

Exchange Time Comparison

※ Performance record with a 350-ton die casting machine

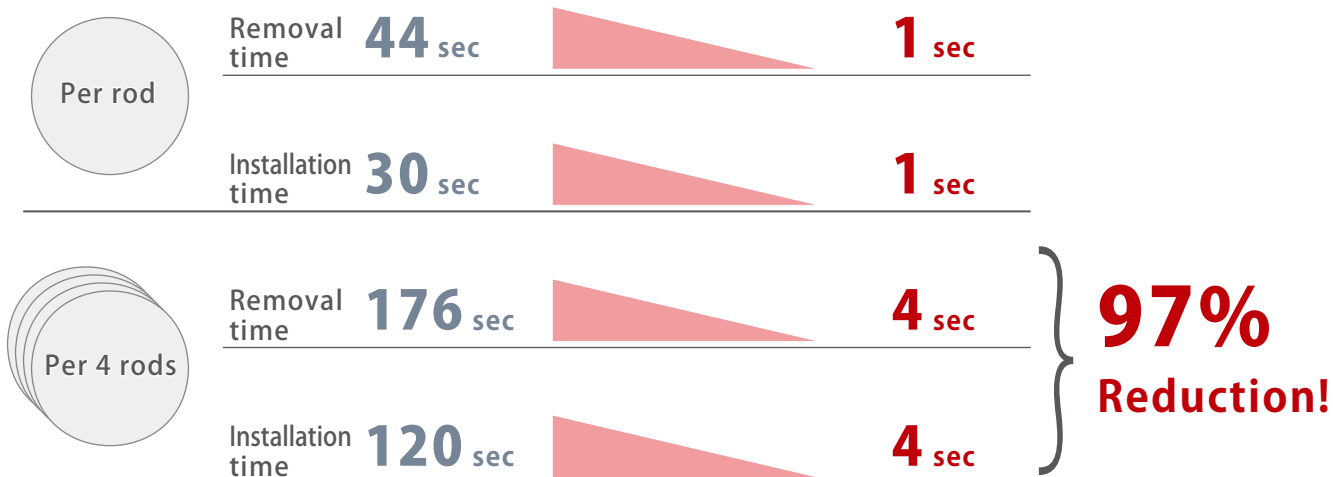

This comparison result was measured at the ejector rod position on the upper operation side, which is the most convenient position for operation. In practice, with the double nut method, the tight space on the non-operation side makes work difficult and more time-consuming, so even greater effects can be expected. (The ejector coupler method requires no tools and ensures easy operation even in tight spaces.)

Push in Smoothly, Lock Securely!

Released State

Pull out the coupler to release.

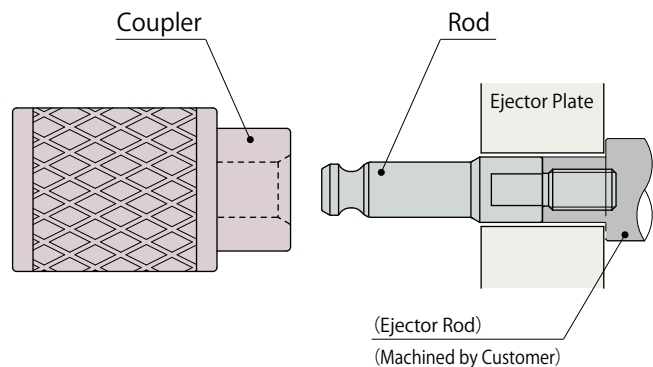
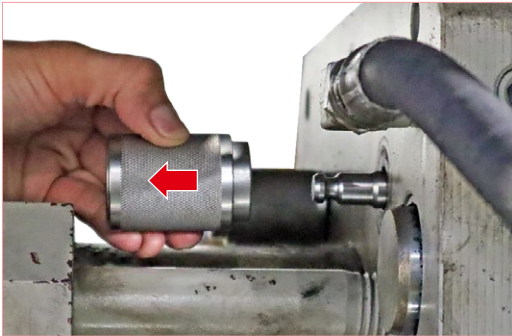

Locked State

Push in the coupler to lock.

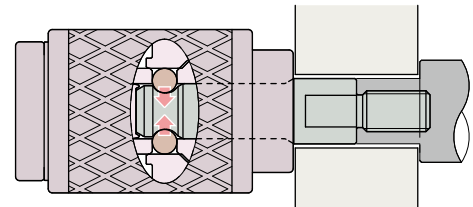
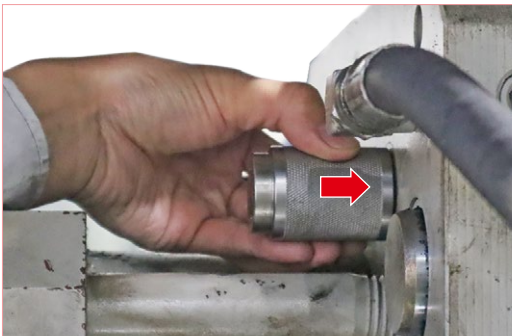

※The product shown in the photo differs in shape from the standard model.

By simply push in the coupler, the steel balls come out with internal spring and mechanically lock the coupler and rod.

Simple Setup

No tools required, no interference with long wrenches, and easy installation and removal even in tight spaces on the non-operation side. With a small die casting machine, operations can be easily performed without moving around to the non-operation side.

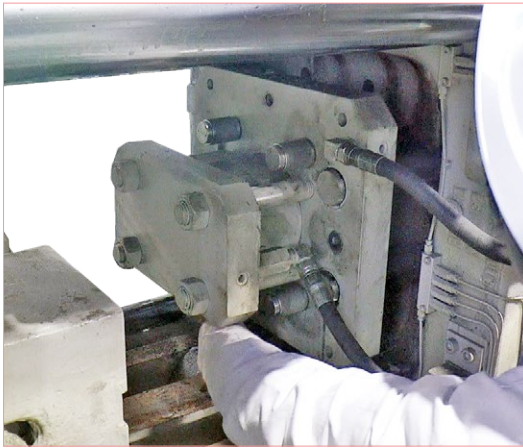

Easy operation even in tight spaces!

User-friendly

With the double nut method, installation gap must be adjusted each time. However, the manual ejector coupler only requires adjustment during initial setup, eliminating the need for repeated adjustments. No specialized skills or experience required—easy to operate for anyone.

Double Nut Method

Precise gap adjustments require experience...

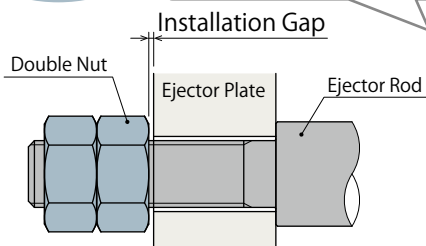

Ejector Coupler Method

Simply push the coupler into the rod. Anyone can do it!

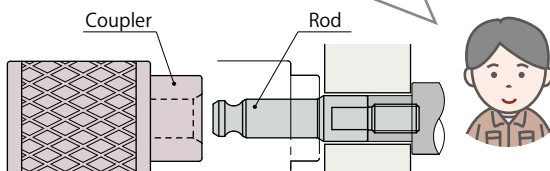

Safe

Reduced installation and removal time minimizes dangerous work behind the movable platen!

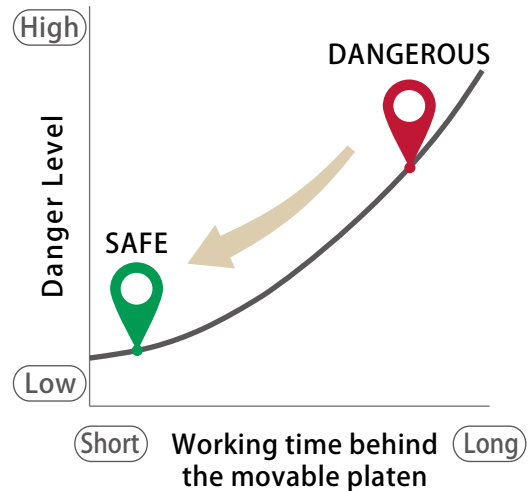

Compatible with C-plate

When installing a mold that does not require a C-plate, the C-plate must be removed. With the ejector coupler method, the C-plate can be easily removed from the ejector plate. Installation and removal during C-plate maintenance can also be performed quickly.

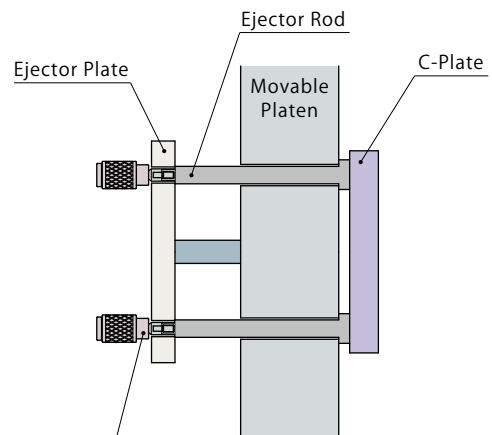

Manual Ejector Coupler

Quick installation and removal!

Model No. Indication



Coupler **PMH 018 0 - C**

1 2



Rod **PMH 018 0 - R**

1 2

1 Ejector Plate Hole Diameter

018 : Ejector Plate Hole Diameter ϕ 18~21 mm

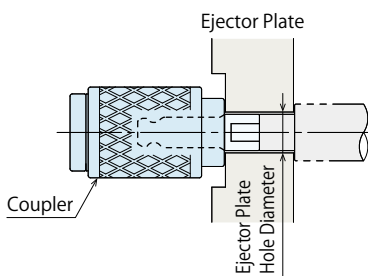

2 Design No.

0 : Revision Number

1 Ejector Plate Hole Diameter

018 : Ejector Plate Hole Diameter ϕ 18~19 mm

020 : Ejector Plate Hole Diameter ϕ 20~21 mm

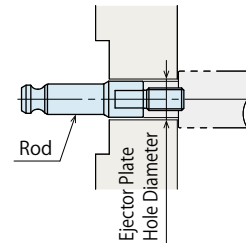

2 Design No.

0 : Revision Number

Specifications

Model No.	Coupler	PMH0180-C	
	Rod	PMH0180-R	PMH0200-R
Max. Allowable Pulling Capacity	kN	7.0	10.0
Spring Force	N	10 ~ 28	
Operating Temperature	°C	0 ~ 120	
Ejector Plate Hole Diameter	mm	ϕ 18 ~ 19	ϕ 20 ~ 21

Note :

1. Make sure that the ejector plate hole is cleaned before use. Contaminants entering into the coupler lead to malfunction.

External Dimensions

Coupler

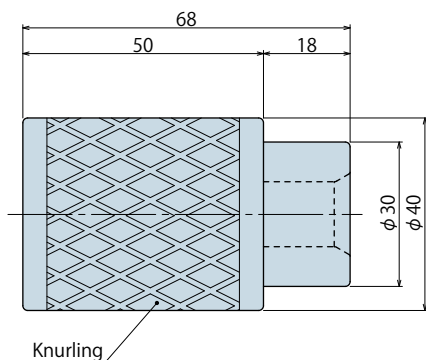

Rod

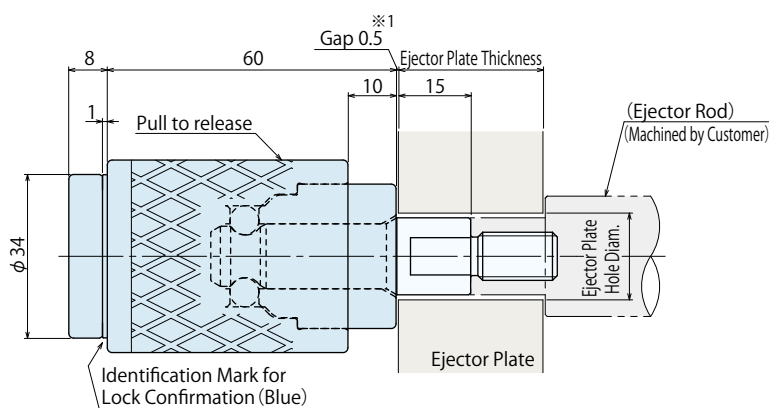
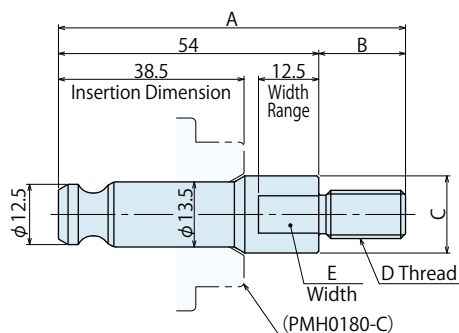

External Dimension and Machining Dimension Lists

Rod

Model No.	PMH0180-R	PMH0200-R
Ejector Plate Hole Diameter	$\phi 18 \sim 19$	$\phi 20 \sim 21$
A	72	76
B	18	22
C	16	18
D	M10 \times 1.5	M12 \times 1.75
E	14	16
Tightning Torque $\ast 2$ (N · m)	50	80

Notes:

$\ast 1$. Design the ejector rod with a gap (0.5mm) between the ejector plate and coupler at the ejector plate backward position in order to prevent the load applied on the connecting part of the manual ejector coupler.

Make sure to install return pins since the ejector pin cannot be fully moved backward due to the gap.

$\ast 2$. Insufficient tightening torque causes looseness and breakage.

1. When connecting the manual ejector coupler, please confirm there is no interference with the ejector plate.

If any interference occurs, we can provide special solutions. Please contact us.

● Cautions

● Notes for Design

- 1) Check Specifications
 - The diecast machine/coupler device should be handled and maintained by qualified personnel.
- 2) When using multiple couplers, please ensure proper leveling.
 - Adjust to ensure that each coupler receives an even load.
- 3) Do not connect couplers when contaminants are adhered.
 - If there are contaminants adhered on edge of each coupler, make sure to remove them with air blow. Otherwise it cannot be connected properly.
- 4) Install mold locating bars.

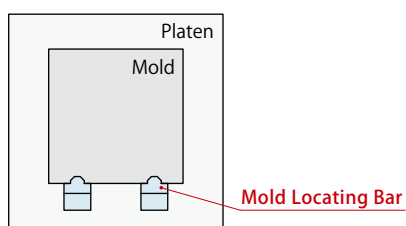

- 5) Install return pins.

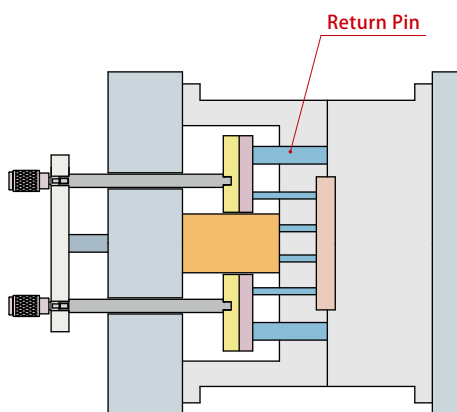

● Installation Notes

1) Installation of the Rod

- For installation of PMH-R : Rod, tighten it with the torque shown in the following list. Insufficient tightening torque causes looseness and breakage.

Model No.	Thread Size	Tightening Torque (N · m)
PMH0180-R	M10×1.5	50
PMH0200-R	M12×1.75	80

2) Make sure that the ejector plate hole is cleaned before use.

- Contaminants entering into the coupler lead to malfunction.

● Cautions

● Notes on Handling

- 1) It should be handled by qualified personnel.
- 2) Do not handle or remove the product unless the safety is ensured.
 - ① The machine and equipment can only be inspected or prepared when it is confirmed that the preventive devices are in place.
 - ② Before the product is removed, make sure that the above-mentioned safety measures are in place.
 - ③ After stopping the machine, do not remove the product until the temperature cools down.
 - ④ Make sure there is no abnormality in the respective parts before restarting the machine or equipment.
- 3) Do not disassemble or modify.
 - If the product is taken apart or modified, the warranty will be voided even within the warranty period.
- 4) Do not touch the product while it is working.
 - Otherwise, your hands may be injured due to clinching.
- 5) After connection, ensure that the identification mark for lock confirmation is visible and that the coupler is securely engaged.

● Maintenance/Inspection

- 1) Removal of the Product
 - Before the product is removed, make sure that the preventive devices and the safety measures are in place. Also, make sure there is no abnormality in the bolts and respective parts before restarting.
- 2) Periodically ensure that the rods are securely tightened.
- 3) Make sure there is smooth action and no abnormal noise.
 - Especially when it is restarted after being left unused for a long period, make sure it can be operated properly.
- 4) The products should be stored in the cool and dark place without direct sunshine or moisture.
- 5) Please contact us for overhaul and repair.

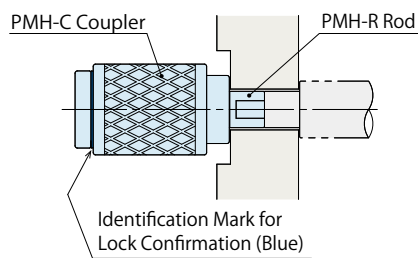

● Warranty

1) Warranty Period

- The product warranty period is 18 months from shipment from our factory or 12 months from initial use, whichever is earlier.

2) Warranty Scope

- If the product is damaged or malfunctions during the warranty period due to faulty design, materials or workmanship, we will replace or repair the defective part at our expense.
Defects or failures caused by the following are not covered.

- ① If the stipulated maintenance and inspection are not carried out.
- ② If the product is used while it is not suitable for use based on the operator's judgment, resulting in defect.
- ③ If it is used or handled inappropriately by the operator.
(Including damage caused by the misconduct of the third party.)
- ④ If the defect is caused by reasons other than our responsibility.
- ⑤ If repair or modifications are carried out by anyone other than Kosmek, or without our approval and confirmation, it will void warranty.
- ⑥ Other damages caused by natural disasters or calamities not attributable to our company.
- ⑦ Parts or replacement expenses due to parts consumption and deterioration. (Such as rubber, plastic, seal material and some electric components.)

Damages excluding from direct result of a product defect shall be excluded from the warranty.

Watch the description video>>>



Application example video
of Manual Ejector Coupler is
available on our website.

https://www.kosmek.co.jp/php_file/video_products.php?id=257&lang=2

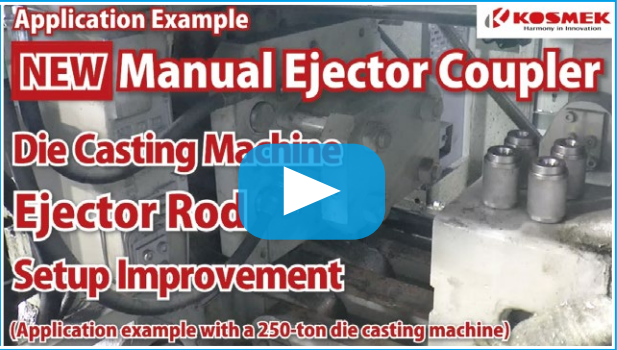

KOSMEK LTD.

▶ <https://www.kosmek.com/>

HEAD OFFICE 1-5, 2-chome, Murotani, Nishi-ku, Kobe-city, Hyogo, Japan 651-2241
TEL.+81-78-991-5162 FAX.+81-78-991-8787

United States of America SUBSIDIARY	KOSMEK (USA) LTD. 650 Springer Drive, Lombard, IL 60148 USA TEL. +1-630-620-7650 FAX. +1-630-620-9015
MEXICO BRANCH OFFICE	KOSMEK USA MEXICO BRANCH OFFICE Av. Loma Pinal de Amoles 320-piso PH oficina 504 interior 13, Vista Dorada, 76060 Santiago de Querétaro, Qro. Mexico TEL. +52-442-851-1377
EUROPE SUBSIDIARY	KOSMEK EUROPE GmbH Schleppeplatz 2 9020 Klagenfurt am Wörthersee Austria TEL. +43-463-287587 FAX. +43-463-287587-20
CHINA SUBSIDIARY	KOSMEK (CHINA) LTD. Room601, RIVERSIDE PYRAMID No.55, Lane21, Pusan Rd, Pudong Shanghai 200125, China TEL. +86-21-54253000
INDIA BRANCH	KOSMEK LTD. - INDIA 4A/Old No:649, Ground Floor, 4th D cross, MM Layout, Kavalbyrasandra, RT Nagar, Bangalore -560032 India TEL.+91-9880561695
THAILAND REPRESENTATIVE OFFICE	KOSMEK Thailand Representation Office No.139, Blue Chips Building, 4th Floor, Room No.422, Soi Sukhumvit 63 (Thong Lor 10), Sukhumvit Rd, Khlong Tan Nuea, Wattana, Bangkok 10110, Thailand TEL. +66(0)2-059-2010

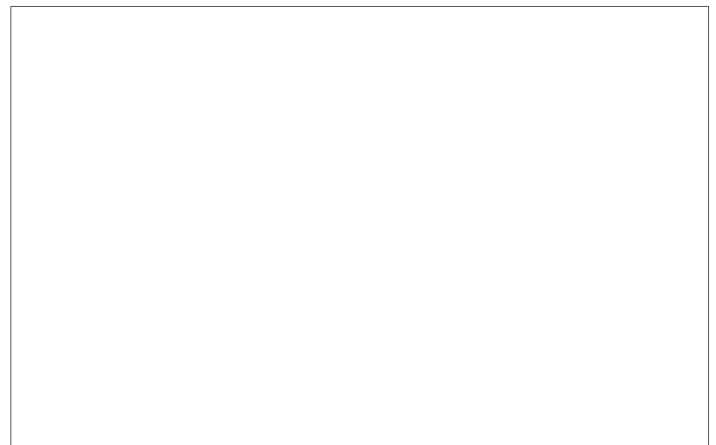

- For Further Information on Unlisted Specifications and Sizes, Please call us.
- Specifications in this Leaflet are Subject to Change without Notice.

